

E8CC with Built-in Microcomputer and Digital Display

- Withstands a pressure of 490 kPa and highly reliable.
- Incorporates a two-turn pressure adjuster ensuring easy pressure setting.



 Be sure to read *Safety Precautions* on page 4.

Ordering Information

Digital display	Pressure range		ON/OFF output	Linear output	Model
Yes	Positive pressure	0 to 98 kPa	NPN open collector	1 to 5 V	E8CC-A01C
	Negative pressure	0 to -101 kPa			E8CC-AN0C
	Positive pressure	0 to 980 kPa			E8CC-B10C

Ratings and Specifications

Item	Model	E8CC-A01C	E8CC-AN0C*	E8CC-B10C
Power supply voltage		12 to 24 VDC $\pm 10\%$ with a ripple (p-p) of 5% max.		
Current consumption		30 mA max.		
Pressure type		Gauge pressure		
Permissible pressure range		0 to 98 kPa	0 to -101 kPa	0 to 980 kPa
Pressure setting range		0 to 98 kPa	0 to -101 kPa	0 to 980 kPa
Pressure indication unit		kPa		
Withstand pressure		490 kPa	1.5 MPa	
Applicable material		Noncorrosive and nonflammable gases		
Repeat accuracy (ON/OFF output)		$\pm 1\%$ FS max.		
Accuracy (linear output)		$\pm 3\%$ FS max.		
Differential travel (ON/OFF output)		2% FS max.		
Linearity (linear output)		$\pm 1\%$ FS max.		
Response time		5 ms max.		
Linear output		1 to 5 V with an output impedance of 20 Ω and a permissible resistive load of 10 k Ω min.		
ON/OFF output		NPN open collector		
	Load current	80 mA max.		
	Output applied voltage	30 VDC max.		
	Residual voltage	1 V max. (with a load current of 80 mA) and 0.4 V max. (with a load current of 20 mA)		
Protection circuits		Reversed power supply connection and load short-circuiting		
Display (See note.)		2 ^{1/2} -digit LCD, operation indicator (red)		
Display accuracy		$\pm 3\%$ FS ± 1 digit max. (within a temperature range between 0°C and 50°C)		
		$\pm 4\%$ FS ± 1 digit max. (within a temperature range between 50°C and 55°C)		
		$\pm 5\%$ FS ± 1 digit max. (within a temperature range between -10°C and 0°C)		
Ambient temperature		Operating: -10°C to 55°C (with no icing) Storage: -25°C to 70°C (with no icing)		
Ambient humidity		Operating/Storage: 35% to 95% (with no condensation)		
Temperature influence		$\pm 0.12\%$ FS/°C between 0°C and 50°C and $\pm 0.2\%$ FS/°C max. between -10°C and 0°C or 50°C and 55°C		
Voltage influence		$\pm 1.5\%$ FS max.		
Insulation resistance		50 M Ω min. (at 500 VDC) between current carrying parts and case		
Dielectric strength		1,000 VAC for 1 min		
Vibration resistance (destruction)		10 to 500 Hz, 1.5-mm double amplitude or 100 m/s ² for 2 hours each in X, Y, and Z directions		
Shock resistance (destruction)		1,000 m/s ² 3 times each in X, Y, and Z directions		
Degree of protection		IEC 60529 IP50		
Pressure inlet		R(PT)1/8, and M5 female screw		
Connection method		Pre-wired (Standard cable length: 2 m)		
Weight (packed state)		Approx. 80 g		
Material	Pressure port	Aluminum		
Accessories		Instruction manual, DIN track mounting bracket		

Note: An example of a 2^{1/2}-digit display is shown below.

	Rated pressure range	Digital display		
		3rd digit	2nd digit	1st digit
Positive pressure	0 to 98 kPa		9	8
	0 to 980 kPa		9	8
Negative pressure	0 to -101 kPa	---	1	0

Note: The display values shown above are for when the maximum rated pressure is applied.

* These models are negative-pressure models.

Engineering Data (Reference Value)

Linear Output Fluctuation vs. Temperature
E8CC-A01C

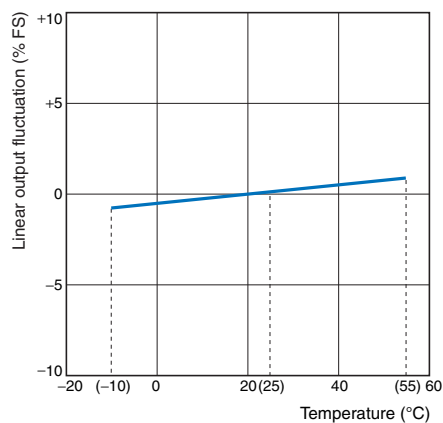

Linear Output Voltage vs. Pressure
E8CC-A01C

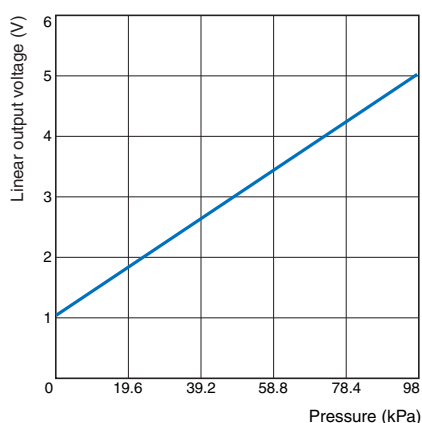

Operating Pressure vs. Temperature
E8CC-A01C

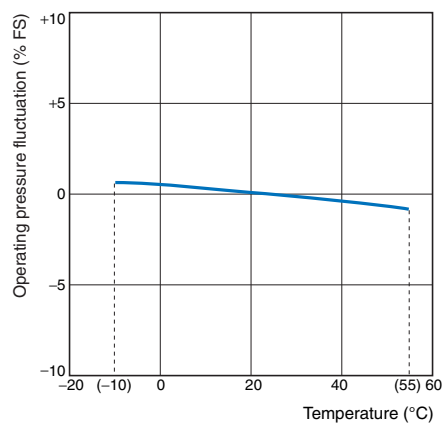

Linearity
E8CC-A01C

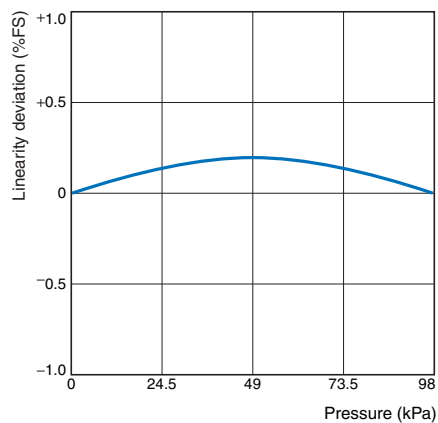

Operating Pressure Fluctuation vs. Voltage
E8CC-AN0C

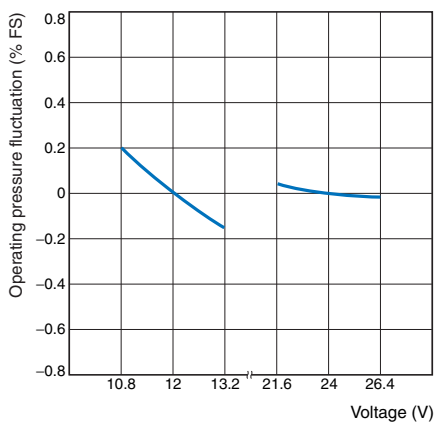

Linear Output Fluctuation vs. Voltage
E8CC-AN0C

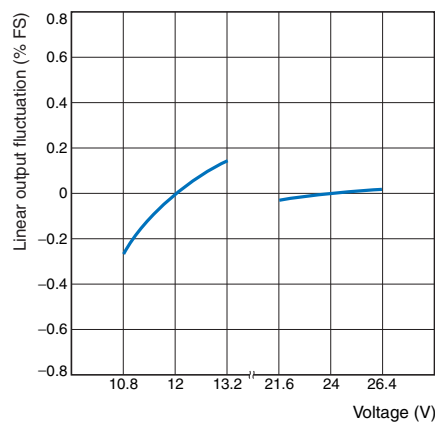

I/O Circuit Diagrams

NPN Output

Model	Timing Charts	Output Circuits
E8CC-A01C E8CC-B10C		
E8CC-AN0C		

Safety Precautions

⚠ WARNING

This product is not designed or rated for ensuring safety of persons. Do not use it for such purposes.



Precautions for Correct Use

Do not use the product in atmospheres or environments that exceed product ratings.

● Mounting

Diaphragm

- If the diaphragm is damaged, the Pressure Sensor will not operate properly. Do not insert a screwdriver or steel wire into the interior of the pressure-sensitive parts through the pressure inlet.

Mounting

- The pressure inlet has an R (PT)1/8 taper screw and an M5 female screw. Apply sealing tape around a screw that conforms to JIS Standards so that no pressure leakage will occur.
- Do not apply a tightening torque higher than 3.9 N·m.
- If the Pressure Sensor is directly connected to a conduit, be sure to apply a wrench to the pressure inlet. Do not apply the wrench to the plastic case.

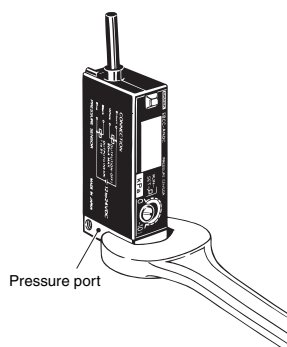

DIN Track Mounting Bracket (E8CC)

● Mounting

1. Fit the front part onto the bracket.
2. Press the rear part onto the bracket.

● Removing

3. Apply a flat-blade screwdriver to the rear hook. Then the Pressure Sensor can be removed with ease.

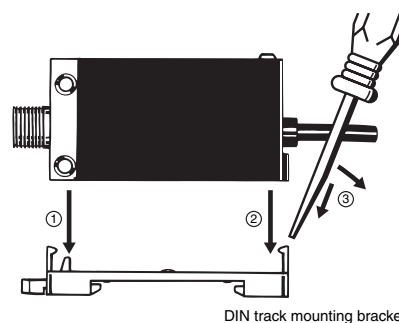

DIN track mounting bracket

● Wiring

- If no linear output is used, cut off the black lead wire and apply insulation tape to the lead wire so that it will not come in contact with any other terminal.

● Adjustment

Setting the Pressure on the E8CC

1. Set the mode selector to SET.



2. Turn the pressure adjuster to the desired pressure.

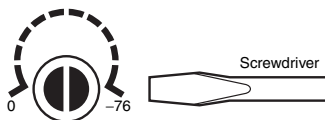

3. Set the mode selector to RUN.



The E8CC has, however, normal output in SET mode. Change in pressure setting is possible in RUN mode by turning the pressure adjuster. Do not turn the pressure adjuster after the pressure adjuster has been set to the desired pressure.

Indications

Display	Mode	Operating status	Description	Permissible range			
				Positive pressure		Negative pressure	
				E8CC -A01C	E8CC -B10C	E8CC -AN0C	
30 (for 30 kPa)	RUN	Normal	Displays the imposed pressure within the permissible range.	0 to 98 kPa	0 to 980 kPa	0 to -101 kPa	
	SET	Normal	Displays the ON-point setting pressure within the permissible range				
--	RUN	Abnormal pressure imposition	<ul style="list-style-type: none"> Positive Pressure: Indicates that the imposed pressure is lower than the permissible range. Negative Pressure: Indicates that the imposed pressure is higher than the permissible range. The E8CC is, however, in normal output operation in both cases. 				
	SET	Abnormal pressure setting	<ul style="list-style-type: none"> Positive Pressure: Indicates that ON-point setting pressure value is lower than the permissible range. Negative Pressure: Indicates that ON-point setting pressure is higher than the permissible range. The E8CC is, however, in normal output operation in both cases. 				
FF	RUN	Abnormal pressure imposition	Indicates that the imposed pressure is higher than the permissible range.				---
	SET	Abnormal pressure setting	<ul style="list-style-type: none"> Positive Pressure: Indicates that ON-point setting pressure value is higher than the permissible range. Negative Pressure: Indicates that ON-point setting pressure is lower than the permissible range. The E8CC is, however, in normal output operation in both cases. 				
LE	RUN	Load over-current	Indicates that the output transistor has excessive load current, in which case, the output of the E8CC is turned OFF and this display flashes until the condition returns to normal. Check the output wiring if this display flashes.				
	SET						
SH	RUN	Element destruction	Indicates that the Pressure Sensor element is damaged due to the imposition of excessive pressure or other reasons, in which case, the output of the E8CC is turned OFF. If this display appears, the E8CC can no longer be used.				
	SET						

Dimensions

E8CC

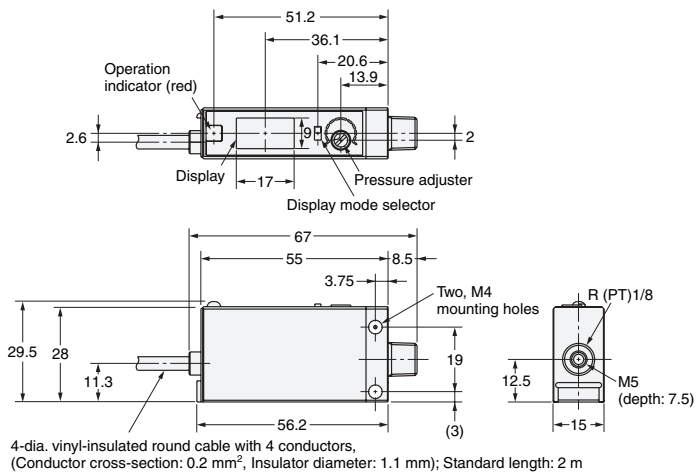
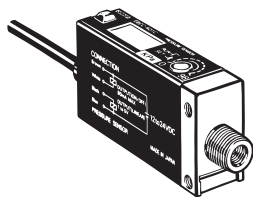

Mounted to a DIN Track Mounting Bracket

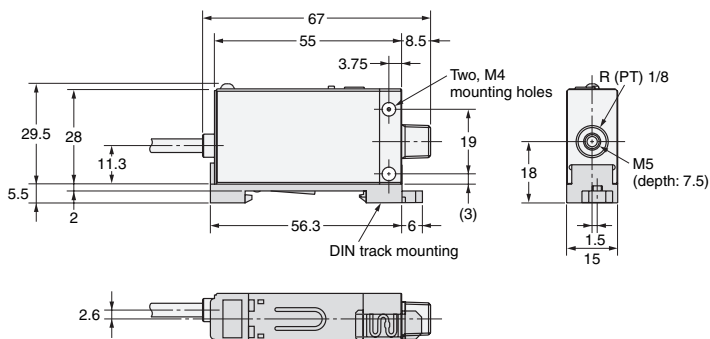
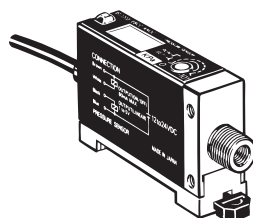

In the interest of product improvement, specifications are subject to change without notice.

Terms and Conditions Agreement

Read and understand this catalog.

Please read and understand this catalog before purchasing the products. Please consult your OMRON representative if you have any questions or comments.

Warranties.

(a) Exclusive Warranty. Omron's exclusive warranty is that the Products will be free from defects in materials and workmanship for a period of twelve months from the date of sale by Omron (or such other period expressed in writing by Omron). Omron disclaims all other warranties, express or implied.

(b) Limitations. OMRON MAKES NO WARRANTY OR REPRESENTATION, EXPRESS OR IMPLIED, ABOUT NON-INFRINGEMENT, MERCHANTABILITY OR FITNESS FOR A PARTICULAR PURPOSE OF THE PRODUCTS. BUYER ACKNOWLEDGES THAT IT ALONE HAS DETERMINED THAT THE PRODUCTS WILL SUITABLY MEET THE REQUIREMENTS OF THEIR INTENDED USE.

Omron further disclaims all warranties and responsibility of any type for claims or expenses based on infringement by the Products or otherwise of any intellectual property right. (c) Buyer Remedy. Omron's sole obligation hereunder shall be, at Omron's election, to (i) replace (in the form originally shipped with Buyer responsible for labor charges for removal or replacement thereof) the non-complying Product, (ii) repair the non-complying Product, or (iii) repay or credit Buyer an amount equal to the purchase price of the non-complying Product; provided that in no event shall Omron be responsible for warranty, repair, indemnity or any other claims or expenses regarding the Products unless Omron's analysis confirms that the Products were properly handled, stored, installed and maintained and not subject to contamination, abuse, misuse or inappropriate modification. Return of any Products by Buyer must be approved in writing by Omron before shipment. Omron Companies shall not be liable for the suitability or unsuitability or the results from the use of Products in combination with any electrical or electronic components, circuits, system assemblies or any other materials or substances or environments. Any advice, recommendations or information given orally or in writing, are not to be construed as an amendment or addition to the above warranty.

See <http://www.omron.com/global/> or contact your Omron representative for published information.

Limitation on Liability; Etc.

OMRON COMPANIES SHALL NOT BE LIABLE FOR SPECIAL, INDIRECT, INCIDENTAL, OR CONSEQUENTIAL DAMAGES, LOSS OF PROFITS OR PRODUCTION OR COMMERCIAL LOSS IN ANY WAY CONNECTED WITH THE PRODUCTS, WHETHER SUCH CLAIM IS BASED IN CONTRACT, WARRANTY, NEGLIGENCE OR STRICT LIABILITY.

Further, in no event shall liability of Omron Companies exceed the individual price of the Product on which liability is asserted.

Suitability of Use.

Omron Companies shall not be responsible for conformity with any standards, codes or regulations which apply to the combination of the Product in the Buyer's application or use of the Product. At Buyer's request, Omron will provide applicable third party certification documents identifying ratings and limitations of use which apply to the Product. This information by itself is not sufficient for a complete determination of the suitability of the Product in combination with the end product, machine, system, or other application or use. Buyer shall be solely responsible for determining appropriateness of the particular Product with respect to Buyer's application, product or system. Buyer shall take application responsibility in all cases.

NEVER USE THE PRODUCT FOR AN APPLICATION INVOLVING SERIOUS RISK TO LIFE OR PROPERTY OR IN LARGE QUANTITIES WITHOUT ENSURING THAT THE SYSTEM AS A WHOLE HAS BEEN DESIGNED TO ADDRESS THE RISKS, AND THAT THE OMRON PRODUCT(S) IS PROPERLY RATED AND INSTALLED FOR THE INTENDED USE WITHIN THE OVERALL EQUIPMENT OR SYSTEM.

Programmable Products.

Omron Companies shall not be responsible for the user's programming of a programmable Product, or any consequence thereof.

Performance Data.

Data presented in Omron Company websites, catalogs and other materials is provided as a guide for the user in determining suitability and does not constitute a warranty. It may represent the result of Omron's test conditions, and the user must correlate it to actual application requirements. Actual performance is subject to the Omron's Warranty and Limitations of Liability.

Change in Specifications.

Product specifications and accessories may be changed at any time based on improvements and other reasons. It is our practice to change part numbers when published ratings or features are changed, or when significant construction changes are made. However, some specifications of the Product may be changed without any notice. When in doubt, special part numbers may be assigned to fix or establish key specifications for your application. Please consult with your Omron's representative at any time to confirm actual specifications of purchased Product.

Errors and Omissions.

Information presented by Omron Companies has been checked and is believed to be accurate; however, no responsibility is assumed for clerical, typographical or proofreading errors or omissions.