

K3TX Intelligent Signal Processor

Operation Manual

Revised October 1996

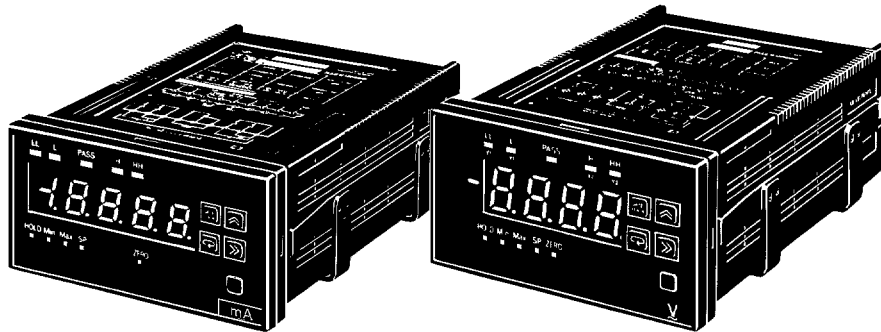



Notice:

OMRON products are manufactured for use according to proper procedures by a qualified operator and only for the purposes described in this manual.

The following conventions are used to indicate and classify precautions in this manual. Always heed the information provided with them. Failure to heed precautions can result in injury to people or damage to the product.

 **DANGER!** Indicates information that, if not heeded, is likely to result in loss of life or serious injury.

 **WARNING** Indicates information that, if not heeded, could possibly result in loss of life or serious injury.

 **Caution** Indicates information that, if not heeded, could result in relatively serious or minor injury, damage to the product, or faulty operation.

OMRON Product References

All OMRON products are capitalized in this manual. The word “Unit” is also capitalized when it refers to an OMRON product, regardless of whether or not it appears in the proper name of the product.

The abbreviation “Ch,” which appears in some displays and on some OMRON products, often means “word” and is abbreviated “Wd” in documentation in this sense.

The abbreviation “PC” means Programmable Controller and is not used as an abbreviation for anything else.

Visual Aids

The following headings appear in the left column of the manual to help you locate different types of information.

Note Indicates information of particular interest for efficient and convenient operation of the product.

1, 2, 3... 1. Indicates lists of one sort or another, such as procedures, checklists, etc.

© OMRON, 1991

All rights reserved. No part of this publication may be reproduced, stored in a retrieval system, or transmitted, in any form, or by any means, mechanical, electronic, photocopying, recording, or otherwise, without the prior written permission of OMRON.

No patent liability is assumed with respect to the use of the information contained herein. Moreover, because OMRON is constantly striving to improve its high-quality products, the information contained in this manual is subject to change without notice. Every precaution has been taken in the preparation of this manual. Nevertheless, OMRON assumes no responsibility for errors or omissions. Neither is any liability assumed for damages resulting from the use of the information contained in this publication.

TABLE OF CONTENTS

SECTION 1

Introduction	1
1-1 Features	2
1-2 Application Examples	3
1-3 Internal Circuit Block Diagram	4

SECTION 2

Front Panel: Nomenclature and Functions	5
2-1 K3TX-□□2□A-□□ (4-digit Basic Model)	6
2-2 K3TX-□□2□B-□□ (with Set Value LED Display)	8
2-3 K3TX-□□2□D-□□ (with Thumbwheel Switches)	10
2-4 K3TX-□D3□A-□□ (4 ¹ / ₂ -digit Basic Model)	12

SECTION 3

Terminals: Nomenclature and Functions	15
3-1 Inputs	16
3-2 Outputs	18

SECTION 4

Mounting	19
4-1 Dimensions	20
4-2 Panel Mounting	20

SECTION 5

Input Models	21
---------------------------	-----------

SECTION 6

Parameter Setting and Operation	25
6-1 Before Setting the Parameters	26
6-2 Parameter Setting	30
6-3 Operations	48

SECTION 7

Troubleshooting	61
Troubleshooting Guide	62

Appendices

A. Standard Models	63
B. Specifications	67

Index	79
--------------------	-----------

Revision History	83
-------------------------------	-----------

About this Manual:

This manual describes the installation and operation of the K3TX Intelligent Signal Processor and includes the sections described below.

Please read this manual carefully and be sure you understand the information provided before attempting to install and operate the K3TX Intelligent Signal Processor.

Section 1 introduces the basic features of the K3TX Intelligent Signal Processor, illustrates some application examples, and provides an internal circuit block diagram.

Section 2 identifies all the major features of the front panel and gives a brief description of each key function.

Section 3 identifies all the input and output features of the terminals and gives a brief description of each terminal.

Section 4 provides the dimensions and environmental conditions needed for mounting the K3TX Intelligent Signal Processor.

Section 5 briefly describes the K3TX Input Models and their range selection.

Section 6 gives comprehensive descriptions on setting the parameters and the operation of the K3TX Intelligent Signal Processor.

Section 7 provides a troubleshooting guide for possible errors during operation and the corrective actions to be taken.

Appendix A provides lists of standard models and options.

Appendix B provides lists of specifications, ratings, factory-set parameters, and interface specifications.



WARNING Failure to read and understand the information provided in this manual may result in personal injury or death, damage to the product, or product failure. Please read each section in its entirety and be sure you understand the information provided in the section and related sections before attempting any of the procedures or operations given.

SECTION 1

Introduction

This section deals with the basic features of the K3TX Intelligent Signal Processor. A brief description is given of each major feature. Possible applications of the K3TX Intelligent Signal Processor are also illustrated. An internal circuit block diagram illustrates how various internal circuits are being used when processing inputs.

1-1	Features	2
1-2	Application Examples	3
1-3	Internal Circuit Block Diagram	4

1-1 Features

The basic features of the K3TX Intelligent Signal Processor are outlined below. These features can be used according to the application. Refer to relevant sections of this manual for details.

Input Range Models

The 4-digit K3TX has 4 Input Range Models: DC Voltage Input Model, DC Current Input Model, AC Voltage Input Model, and AC Current Input Model.

The 4^{1/2}-digit K3TX has 2 Input Range Models: DC Voltage Input Model and DC Current Input Model.

Supply Frequency

The K3TX has 2 sampling periods, 50 Hz (12.5 times/s) and 60 Hz (15 times/s), in order to remove inductive noise.

Lock Timer

When the lock input is ON, measurement is interrupted for a specified period during which all outputs are OFF. The operation can be retriggered if desired.

Prescaling

Input values can be converted by an arbitrary factor and the converted results can be displayed.

Forced Zero (Zero-shift)

By turning the ZERO input ON (by short-circuiting the ZERO input), the process value can be calibrated to zero. This calibration is maintained until the next time the ZERO input signal is turned ON.

Display Refresh Period

A display refresh period among 5 settings can be selected. The display refresh period can range between 1 to 4 s.

Set Values

Measured values are compared with the set values. There is no limitation on the differences in set values among HH, H, L, and LL. The decimal is displayed at the position set in the prescale parameter.

Hysteresis

The set value includes a hysteresis setting to prevent the comparative output status indicators from turning ON/OFF when it should not if the measured value fluctuates in the vicinity of the set value.

Protecting, Checking, and Changing Set Values

The set value can be checked or changed in RUN mode. With the Basic and LED Models, the set value can be protected in RUN mode.

Linear Output Range

The Intelligent Signal Processor outputs a linear voltage or current in proportion to the changes in the measured value.

Maximum/Minimum Values

The maximum and minimum of the values measured since power application or RESET signal input up to the present point are retained. When the RESET signal turns ON when Power is OFF or in setting mode, both the maximum and minimum values are reset to the present value. Even though the maximum and minimum values are retained in memory, the comparative output and BCD output are output in accordance with changes in the measured value, regardless of the display, except as controlled by the HOLD input (see next feature).

Hold Measured Value

When the HOLD input is turned ON during RUN mode, measurement stops and the input measured just before the HOLD input turned ON is held. The displayed value, comparative output, BCD data, etc., are also held.

Test Mode

This function is convenient for checking a system to which the Intelligent Signal Processor is connected, especially when some inputs cannot be operated. The Intelligent Signal Processor simulates an input, changing the display and output conditions.

Teaching Function

This function allows the measured values, comparative outputs, or linear output range to be set as set values while actual measurement is being carried out. This function is useful for setting parameters while checking the operating status of the Intelligent Signal Processor.

1-2 Application Examples

The following diagrams illustrate some potential uses of the K3TX Intelligent Signal Processor.

Detection of Aluminum Deposition

Detects via the E3SA the change in reflected light according to the amount of aluminum deposition on the CRT. The input is processed and displayed in percentage by the prescaling function.

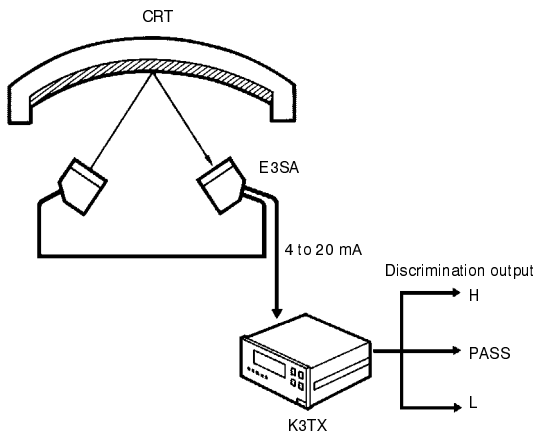

Detection of Improper Packing

Detects the difference between a good and bad seal.

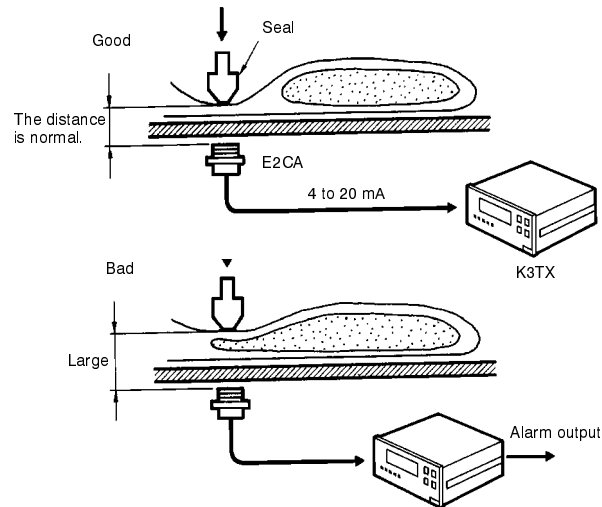

Detection of Dust Exhaust

The change in the density of the dust is detected via the E3SA and discriminated by the K3TX.

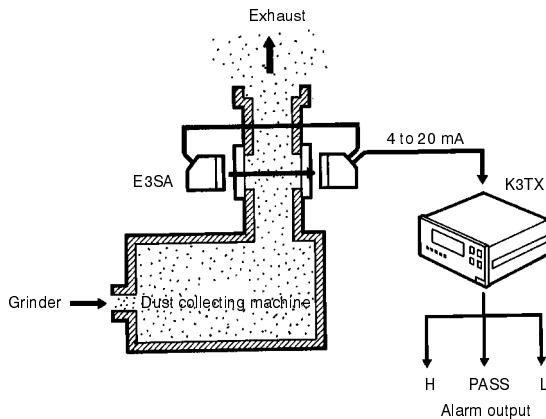

Monitoring of Discharged Powder

The output of the analog photoelectric sensor is processed and displayed by the prescaling function. Monitoring the power level is possible with the BCD data sent to the PC.

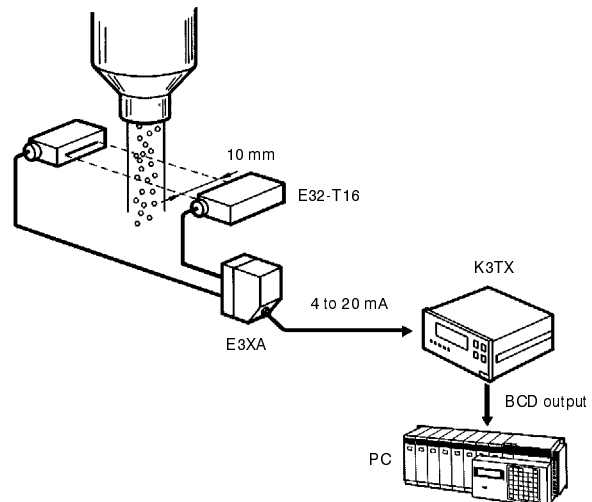

Detection of Warped Object

The warp of the object is converted into the movement of the attachment which the linear proximity sensor detects. The result is displayed and discriminated by the K3TX

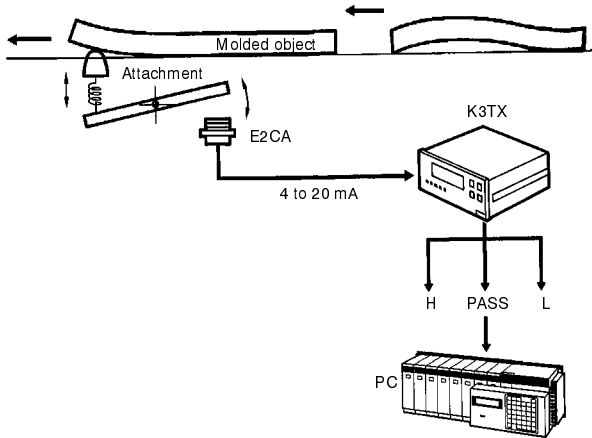

Monitoring of Tank Pressure

The output of the pressure sensor is processed and the pressure is displayed. The integrated monitoring of the operation is possible by sending the linear output data to the CPU.

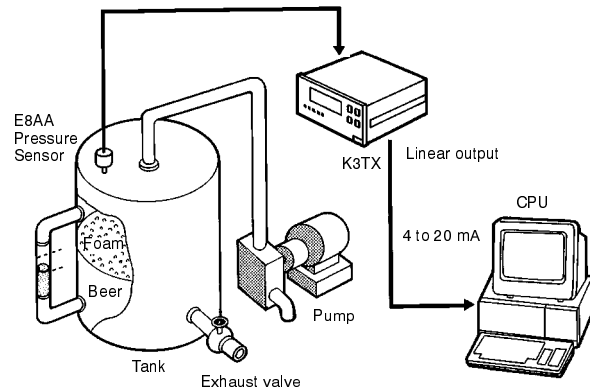

1-3 Internal Circuit Block Diagram

The following schematic illustrates how various internal circuits are being used when processing inputs from sources such as sensors, control inputs, and control power supply.

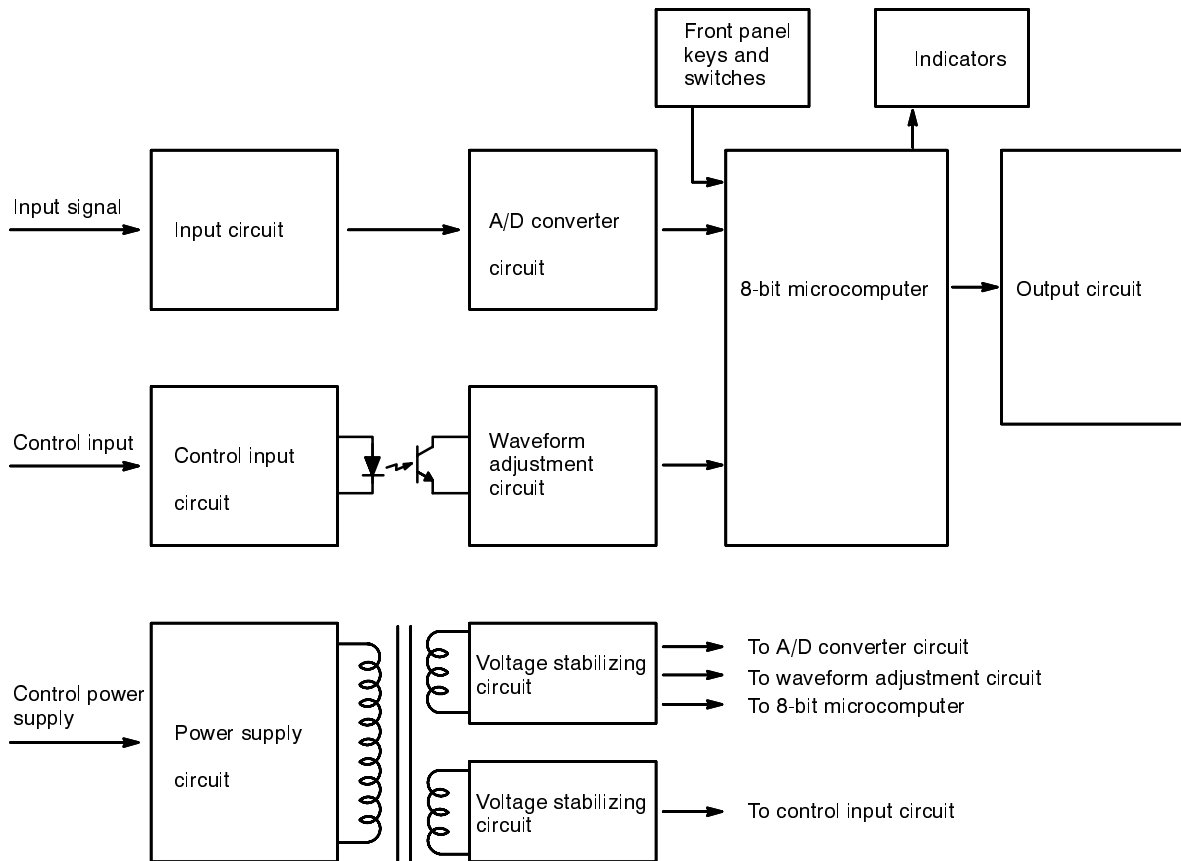

SECTION 2

Front Panel: Nomenclature and Functions

This section gives a general and introductory description of the Intelligent Signal Processor's front panel.



2-1	K3TX-□□2□A-□□ (4-digit Basic Model)	6
2-2	K3TX-□□2□B-□□ (with Set Value LED Display)	8
2-3	K3TX-□□2□D-□□ (with Thumbwheel Switches)	10
2-4	K3TX-□D3□A-□□ (4 ¹ / ₂ -digit Basic Model)	12

2-1 K3TX-□□2□A-□□ (4-digit Basic Model)

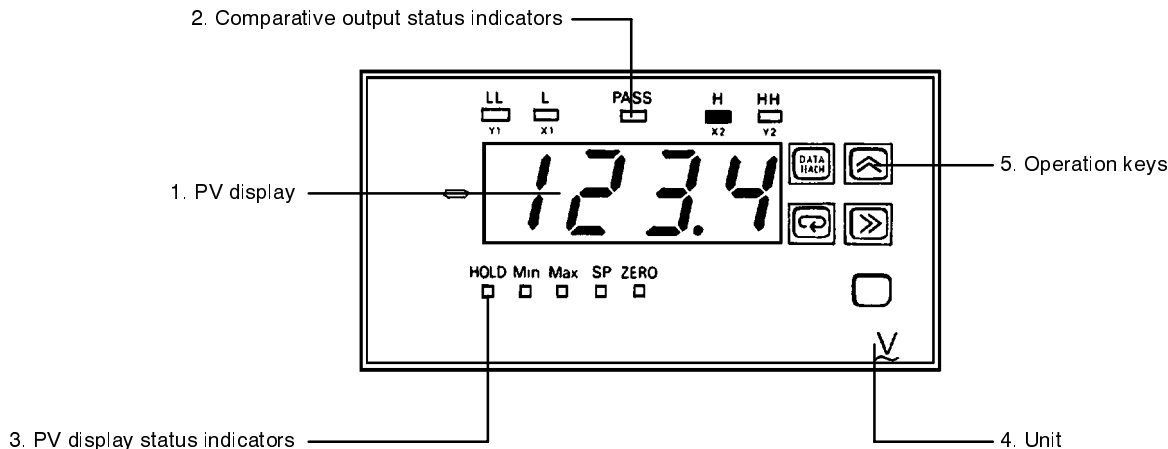
The following diagram identifies the major features found on the K3TX 4-digit Basic Model front panel. The table gives a brief description of the function of each front panel feature.

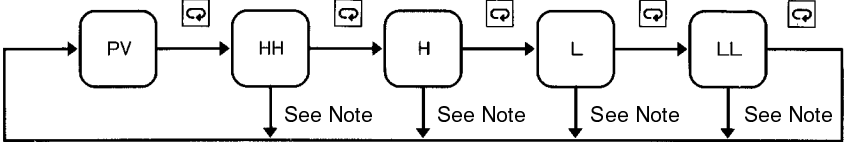
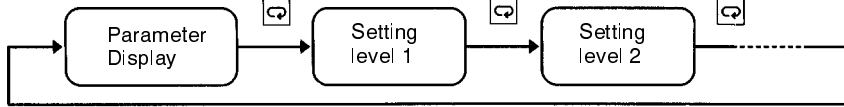
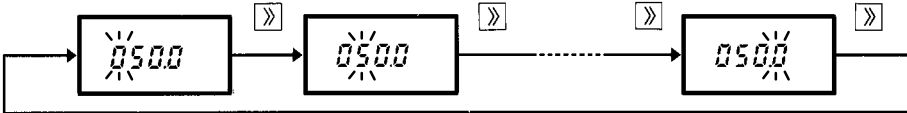
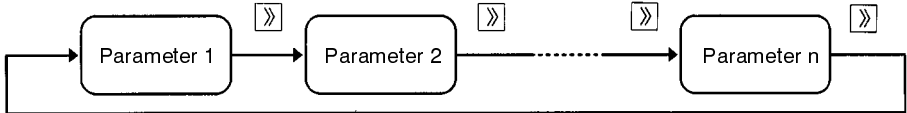

No.	Name	Functions	
1.	PV (process value) display	Displays the process, maximum, and minimum values. Also displays set values while the SP indicator is lit. Displays characters indicating the setting mode and set values. Displays an error message when an error occurs.	
2	Comparative output status indicators	HH	Is lit when HH comparative output status is ON. HH comparative output status turns ON when the measured value exceeds the HH set value. This indicator does not light in models not provided with the comparative output function.
		H	Is lit when H comparative output status is ON. H comparative output status turns ON when the measured value exceeds the H set value. This indicator does not light in models not provided with the comparative output function.
		L	Is lit when L comparative output status is ON. L comparative output status turns ON when the measured value falls below the L set value. This indicator does not light in models not provided with the comparative output function.
		LL	Is lit when LL comparative output status is ON. LL comparative output status turns ON when the measured value falls below the LL set value. This indicator does not light in models not provided with the comparative output function.
		PASS	Is lit when PASS comparative output status is ON. PASS comparative output status turns ON when all HH, H, L, and LL comparative output status are OFF. This indicator does not light in models not provided with the comparative output function.
3	PV display status indicators	HOLD	Is lit when HOLD input is ON. By turning ON the HOLD terminal on the rear panel, the hold function can be effected.
		Min	Indicates that the value displayed on the PV display is the minimum value. To display the minimum value, use the DATA TEACH Key.
		Max	Indicates that the value displayed on the PV display is the maximum value. To display the maximum value, use the DATA TEACH Key.
		SP	Indicates that the value displayed on the PV display is a set value. To display a set value, use the Display Key. This indicator does not light in models not provided with the comparative output function; in this case, no set value can be displayed with the Display Key.
		ZERO	Is lit when the forced zero input signal is ON. By turning ON the ZERO terminal on the rear panel, the ZERO shift function can be effected.
4	Unit	Attach the appropriate label (use the labels supplied as accessories).	

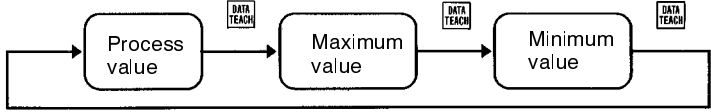

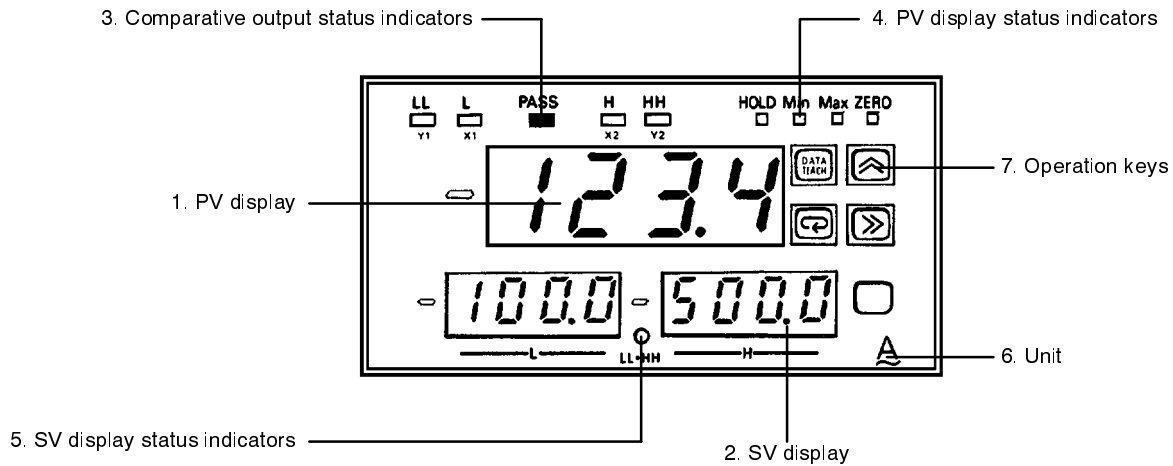

No.	Name	Functions
5	Operation keys Level Key Display Key	<p>Selects the setting mode, in which the setting levels can be changed. For details on the setting levels, refer to 6-1 Before Setting the Parameters.</p> <p>Displays a set value on the PV display. This function is not provided on models not equipped with the comparative output function.</p>  <p>Note: Unless another operation key is pressed within 5 seconds after this key has been pressed, the process value is displayed again.</p> <p>In the setting mode, after a parameter is selected with the Shift Key, the selected setting is enabled with this key; or, the set value is written to memory.</p> 
	Shift Key	<p>Shifts the digit where the set value is to be changed.</p>  <p>Selects a parameter at each setting level.</p>  <p>For details on the setting parameter, refer to 6-2 Parameter Setting.</p>
	Up Key	<p>Increases the set value by one.</p> 
	DATA TEACH Key	<p>Displays the process, maximum, or minimum value.</p>  <p>The teaching function can set an actual measured value as a set value, prescaling input value, or linear output range in setting mode. For details on the teaching function, refer to 6-3-2 Special Functions.</p>

2-2 K3TX-□□2□B-□□ (with Set Value LED Display)

The following diagram identifies the major features found on the K3TX with Set Value LED Display front panel. The table gives a brief description of the function of each front panel feature.

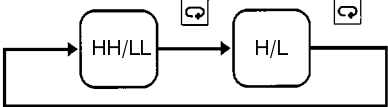
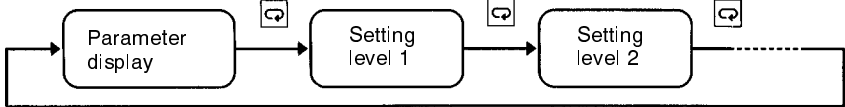

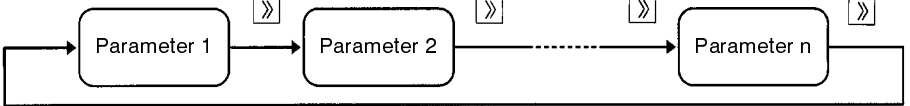
No.	Name	Functions	
1	PV (process value) display	Displays the process, maximum, and minimum values. Displays characters indicating the setting mode and set values. Displays an error message when an error occurs.	
2	SV (set value) display	Displays the set value of a comparative output. In setting mode, displays the set parameter.	
3	Comparative output status indicators	HH	Is lit when HH comparative output status is ON. HH comparative output status turns ON when the measured value exceeds the HH set value.
		H	Is lit when H comparative output status is ON. H comparative output status turns ON when the measured value exceeds the H set value.
		L	Is lit when L comparative output status is ON. L comparative output status turns ON when the measured value falls below the L set value.
		LL	Is lit when LL comparative output status is ON. LL comparative output status turns ON when the measured value falls below the LL set value.
		PASS	Is lit when PASS comparative output status is ON. PASS comparative output status turns ON when all HH, H, L, and LL comparative output status are OFF.
4	PV display status indicators	HOLD	Is lit when HOLD input is ON. By turning ON the HOLD terminal on the rear panel, the hold function can be effected.
		Min	Indicates that the value displayed on the PV display is the minimum value. To display the minimum value, use the DATA TEACH Key.
		Max	Indicates that the value displayed on the PV display is the maximum value. To display the maximum value, use the DATA TEACH Key.
		ZERO	Is lit when the forced zero input signal is ON. By turning ON the ZERO terminal on the rear panel, the ZERO shift function can be effected.
5	SV display status indicators	Indicates whether the displayed set value on the SV display is HH and LL or H and L. The SV display is lit when the set values are HH and LL and not lit when the set values are H and L.	
6	Unit	Attach the appropriate label (use the labels supplied as accessories).	

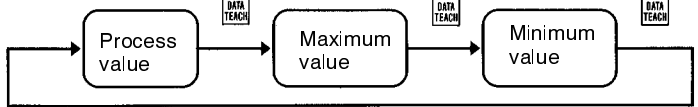
No.	Name	Functions
7	Operation keys Level Key Display Key	<p>Selects the setting mode, in which the setting levels can be changed. For details on the setting levels, refer to 6-1 Before Setting the Parameters.</p> <p>Displays a set value on the SV display.</p>  <p>In the setting mode, after a parameter is selected with the Shift Key, the selected setting is enabled or the set value is written to memory with this key.</p> 
	Shift Key	<p>Shifts the digit where the set value is to be changed.</p>  <p>Selects a parameter at each setting level.</p>  <p>For details on the setting parameter, refer to 6-2 Parameter Setting.</p>
	Up Key	<p>Increases the set value by one.</p> 
	DATA TEACH Key	<p>Displays the process, maximum, or minimum value.</p>  <p>The teaching function can set an actual measured value as a set value or prescaling input value in setting mode. For details on the teaching function, refer to 6-3-2 Special Functions.</p>

2-3 K3TX-□□2□D-□□ (with Thumbwheel Switches)

The following diagram identifies the major features found on the K3TX with Thumbwheel Switches front panel. The table gives a brief description of the function of each front panel feature.

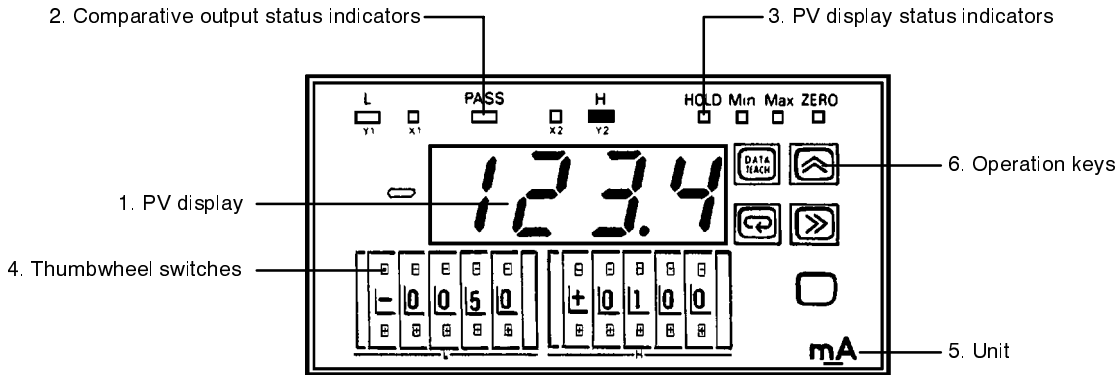

No.	Name	Functions	
1	PV (process value) display	Displays the process, maximum, and minimum values. Displays characters indicating the setting mode and set values. Displays an error message when an error occurs.	
2	Comparative output status indicators	H	Is lit when H comparative output status is ON. H comparative output status turns ON when the measured value exceeds the H set value.
		L	Is lit when L comparative output status is ON. L comparative output status turns ON when the measured value falls below the L set value.
		PASS	Is lit when PASS comparative output status is ON. PASS comparative output status turns ON when all H and L comparative output status are OFF.
3	PV display status indicators	HOLD	Is lit when HOLD input is ON. By turning ON the HOLD terminal on the rear panel, the hold function can be effected.
		Min	Indicates that the value displayed on the PV display is the minimum value. To display the minimum value, use the DATA TEACH Key.
		Max	Indicates that the value displayed on the PV display is the maximum value. To display the maximum value, use the DATA TEACH Key.
		ZERO	Is lit when the forced zero input signal is ON. By turning ON the ZERO terminal on the rear panel, the ZERO shift function can be effected.
4	Thumbwheel switches	Set H and L set values. The set values can be changed at any time regardless of the status of the RUN or setting mode.	
5	Unit	Attach the appropriate label (use the labels supplied as accessories).	

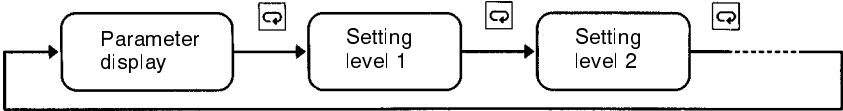
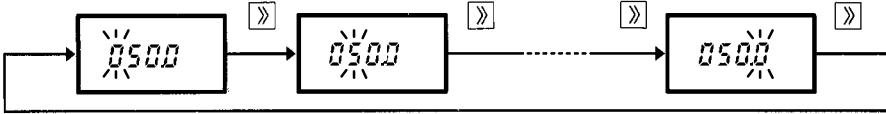
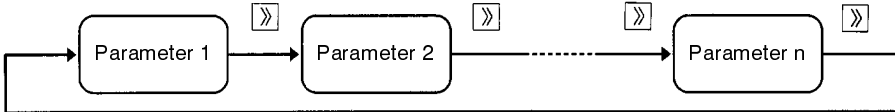
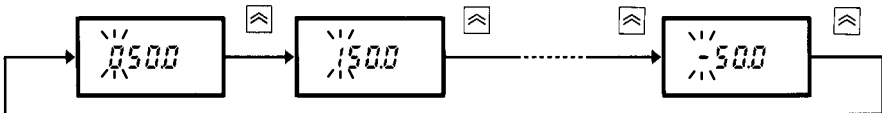
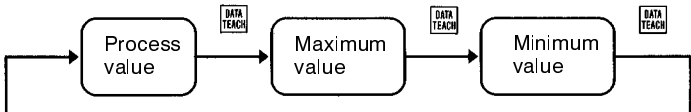
No.	Name	Functions
6	Operation keys	<p>□ Selects the setting mode, in which the set levels can be changed. For details on the set levels, refer to 6-1 Before Setting the Parameters.</p>
	Level Key	<p>⏪ This key is invalid in RUN mode. In the setting mode, after a parameter is selected with the Shift Key, the selected setting is enabled or the set value is written to memory with this key.</p> 
	Display Key	<p>⏩ Shifts the digit where the set value is to be changed.</p>  <p>Selects a parameter at each setting level. For details on the setting parameter, refer to 6-2 Parameter Setting.</p> 
	Shift Key	<p>⏴ Increases the set value by one.</p> 
	Up Key	<p>DATA TEACH □ Displays the process, maximum, or minimum value.</p>  <p>The teaching function can set an actual measured value as a prescaling input value in setting mode. For details on the teaching function, refer to 6-3-2 Special Functions.</p>

2-4 K3TX-□D3□A-□□ (4¹/₂-digit Basic Model)

The following diagram identifies the major features found on the K3TX with 4¹/₂-digit display front panel. The table gives a brief description of the function of each front panel feature.

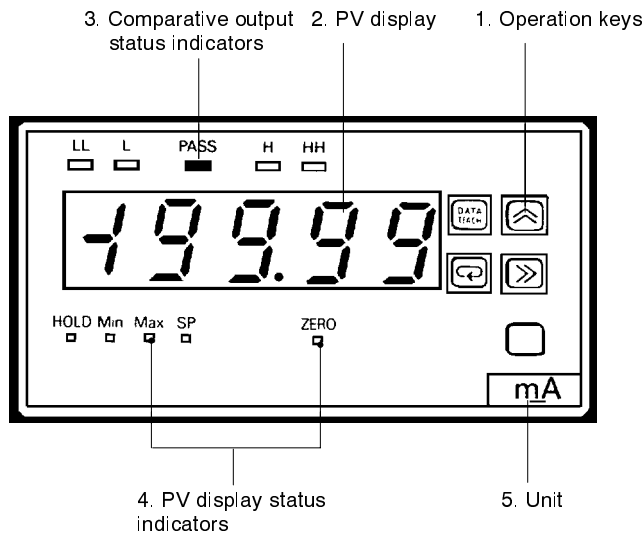

No.	Name	Functions	
1.	PV (process value) display	Displays the process, maximum, and minimum values. Also displays set values while the SP indicator is lit. Displays characters indicating the setting mode and set values. Displays an error message when an error occurs.	
2	Comparative output status indicators	HH	Is lit when HH comparative output status is ON. HH comparative output status turns ON when the measured value exceeds the HH set value. This indicator does not light in models not provided with the comparative output function.
		H	Is lit when H comparative output status is ON. H comparative output status turns ON when the measured value exceeds the H set value. This indicator does not light in models not provided with the comparative output function.
		L	Is lit when L comparative output status is ON. L comparative output status turns ON when the measured value falls below the L set value. This indicator does not light in models not provided with the comparative output function.
		LL	Is lit when LL comparative output status is ON. LL comparative output status turns ON when the measured value falls below the LL set value. This indicator does not light in models not provided with the comparative output function.
		PASS	Is lit when PASS comparative output status is ON. PASS comparative output status turns ON when all HH, H, L, and LL comparative output status are OFF. This indicator does not light in models not provided with the comparative output function.
3	PV display status indicators	HOLD	Is lit when HOLD input is ON. By turning ON the HOLD terminal on the rear panel, the hold function can be effected.
		Min	Indicates that the value displayed on the PV display is the minimum value. To display the minimum value, use the DATA TEACH Key.
		Max	Indicates that the value displayed on the PV display is the maximum value. To display the maximum value, use the DATA TEACH Key.
		SP	Indicates that the value displayed on the PV display is a set value. To display a set value, use the Display Key. This indicator does not light in models not provided with the comparative output function; in this case, no set value can be displayed with the Display Key.
		ZERO	Is lit when the forced zero input signal is ON. By turning ON the ZERO terminal on the rear panel, the ZERO shift function can be effected.
4	Unit	Attach the appropriate label (use the labels supplied as accessories).	

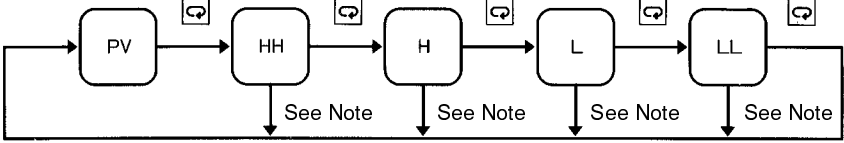
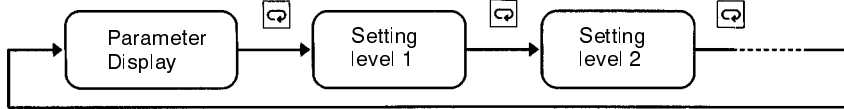
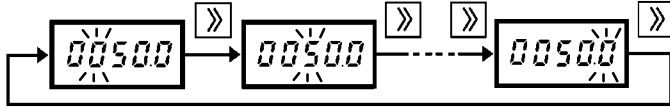
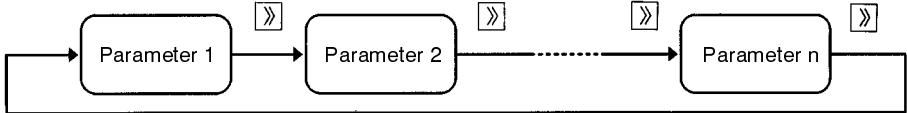
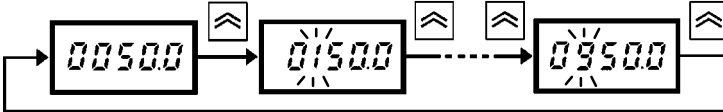
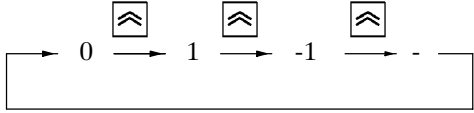
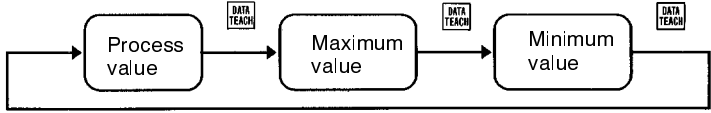
No.	Name	Functions
5	Operation keys Level Key Display Key	<p>Selects the setting mode, in which the setting levels can be changed. For details on the setting levels, refer to 6-1 Before Setting the Parameters.</p> <p>Displays a set value on the PV display. This function is not provided on models not equipped with the comparative output function.</p>  <p>Note: Unless another operation key is pressed within 5 seconds after this key has been pressed, the process value is displayed again.</p> <p>In the setting mode, after a parameter is selected with the Shift Key, the selected setting is enabled with this key; or, the set value is written to memory.</p> 
	Shift Key	<p>Shifts the digit where the set value is to be changed.</p>  <p>Selects a parameter at each setting level.</p>  <p>For details on the setting parameter, refer to 6-2 Parameter Setting.</p>
	Up Key	<p>Used to increment the current digit in the set value by one.</p>  <p>The leftmost digit changes in the following order.</p> 
	DATA TEACH Key	<p>Displays the process, maximum, or minimum value.</p>  <p>The teaching function can set an actual measured value as a set value or prescaling input value in setting mode. For details on the teaching function, refer to 6-3-2 Special Functions.</p>

SECTION 3

Terminals: Nomenclature and Functions

This section gives a general description of the K3TX Intelligent Signal Processor's terminals.

3-1	Inputs	16
3-2	Outputs	18

3-1 Inputs

The K3TX Intelligent Signal Processor's terminal inputs terminal are described in the following diagram and table. The table identifies each terminal and briefly describes its input function.

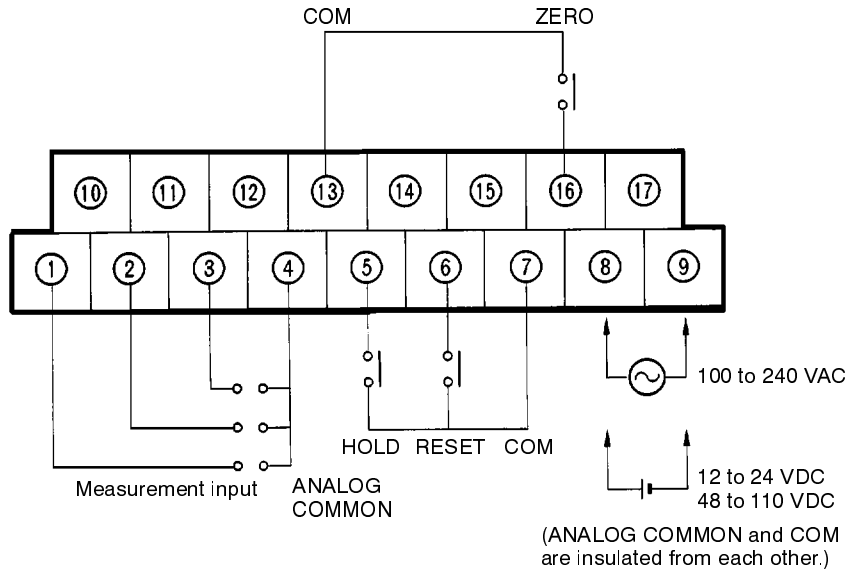

No.	Name	Function
1 to 3	Measurement input	Accepts measurement input. The terminals are selected according to the input range. For details on the connecting terminals and input ranges, refer to <i>5 Input Models</i> .
4	ANALOG COMMON	The common terminal of the measurement input terminals.
5	HOLD (see note)	When the signal input to this terminal (HOLD signal) turns ON, measurement is stopped and the value input immediately before the HOLD signal is retained. The displayed value, comparative outputs, and BCD data are also retained. While the HOLD signal is ON, the hold operation continues. The effect of the hold function is canceled when the HOLD signal is turned OFF.
6	RESET	When the signal input to this terminal (RESET signal) turns ON, the present maximum and minimum values are cleared, and measurement of new maximum and minimum values begins. While the RESET signal is ON, both the maximum and minimum values change with the input values.
7	COM	This is the common terminal for the HOLD, RESET, and ZERO signals. Supply the HOLD, RESET, and ZERO signals as no-voltage contact input signals. To input the signals through a transistor, use the open-collector configuration shown below. <div style="text-align: center;"> </div>
8 9	Power	Supply power to these terminals. Be sure to supply 100 to 240 VAC for AC-operated models, and 12 to 24 VDC or 48 to 110 VDC for DC-operated models.

No.	Name	Function
10 to 12	Unused terminals	---
13	COM	This is the common terminal for the HOLD, RESET, and ZERO signals. Terminals 7 and 13 are connected internally.
14 to 15	Unused terminals	---
16	ZERO	With the ZERO input ON, the input value immediately before the ZERO input was ON is treated as 0.
17	Unused terminal	---

Note Observe the following precautions for the HOLD input:
 When using the K3TX-VA□□□ that is set to an input range of 0 to 400 V with a device that conforms to EN/IEC standards, use the following OMRON-recommended Relay for the HOLD input as shown in the external connection diagram below. With this connection, the K3TX-VA□□□ will conform to EN61010-1 (IEC1010-1). (It must be noted that the K3TX-VA□□□ will not conform to EN/IEC standards if the HOLD input is performed by an open collector.)
 Relay: G2R-1-S Series (File No. R9151251)
 Socket: P2RF-05

External Connection Diagram

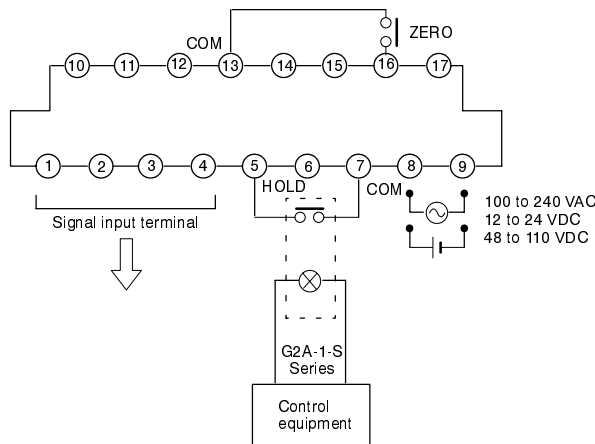

3-2 Outputs

Depending upon the requirements of the receiving unit, the K3TX Intelligent Signal Processor can use one of the following outputs.

K31-C1: Relay (3 Outputs)

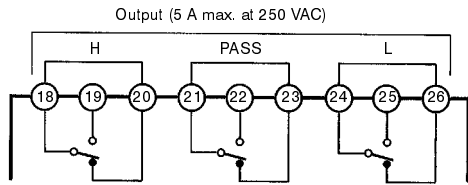

K31-C2: Relay (5 Outputs)

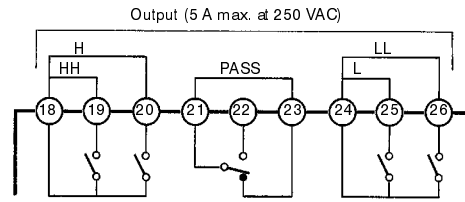

K31-C5: Relay (5 Outputs)

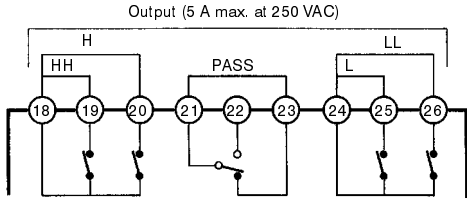

K31-T1: Transistor (NPN Open Collector)

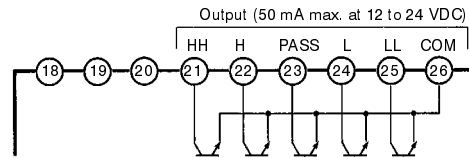

K31-T2: Transistor (PNP Open Collector)

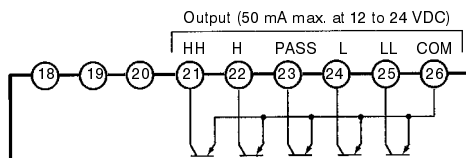

K31-B2: BCD (NPN Open Collector)

(Terminals 32 to 36 are provided only on models with special specifications. Terminals 18 to 21 are provided only on the 4 1/2-digit Series.)

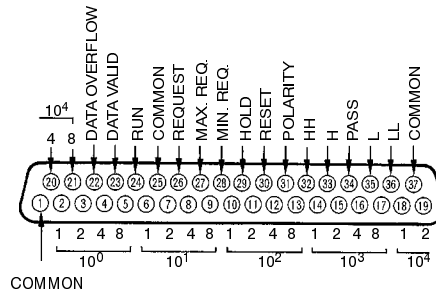

K31-L1, L2, L3: Linear

(Terminals 21 to 26 are provided only on models with special specifications.)

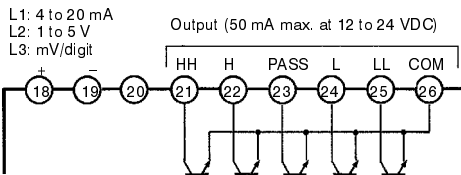

K31-S1: RS-232C

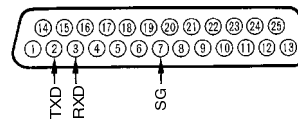

K31-S2: RS-485

(Terminals 21 to 26 are provided only on models with special specifications.)

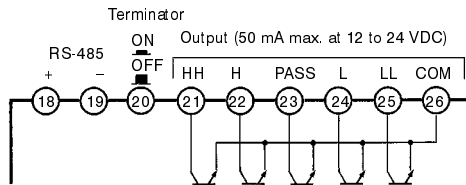

K31-S3: RS-422

(The right connector is provided only on models with special specifications.)

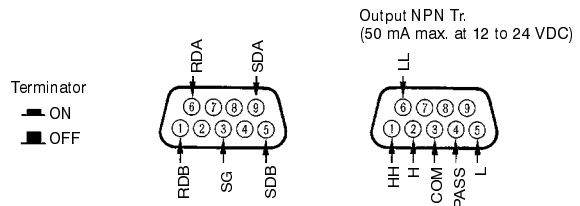

Model with BCD output includes a D-sub 37-pin connector (attachment).
 Plug: XM2A-3701
 Hood: XM2S-3711

For models with an RS-232C terminal, use a D-sub 25-pin connector (sold separately).
 Plug: XM2A-2501
 Hood: XM2S-2511

For models with an RS-422 terminal, use a D-sub 9-pin connector (sold separately).
 Plug: XM2A-0901
 Hood: XM2S-0911

SECTION 4

Mounting

This section provides the dimensions and instructions required for mounting the K3TX Intelligent Signal Processor. Mounting conditions for the Unit are also given.

4-1	Dimensions	20
4-2	Panel Mounting	20

4-1 Dimensions

All dimensions are in millimeters.

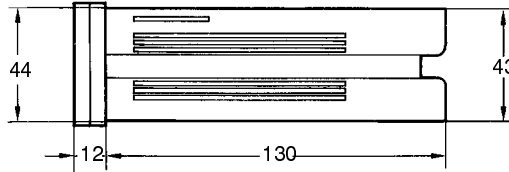
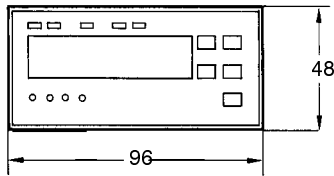
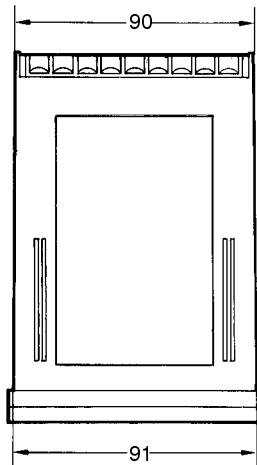

4-2 Panel Mounting

The mounting dimensions of the Intelligent Signal Processor conform to DIN 43700. Recommended panel thickness is 1 to 3.2 mm. Attach the mounting brackets supplied as accessories to the Intelligent Signal Processor from behind and tighten the mounting screws of the brackets to a torque of 5 kgf • cm (0.49 N • m).

Whenever possible, keep the Intelligent Signal Processor horizontal. Do not install the Intelligent Signal Processor where it will be exposed to corrosive gases (especially sulfurized gas and ammonia gas). Do not install the Intelligent Signal Processor where it will be subject to vibration, shock, dust, or high humidity. The ambient temperature of the installation site must be within -10° to 55°C.

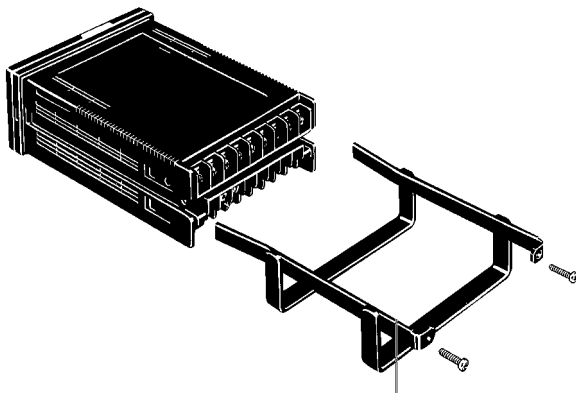

Panel Cutout

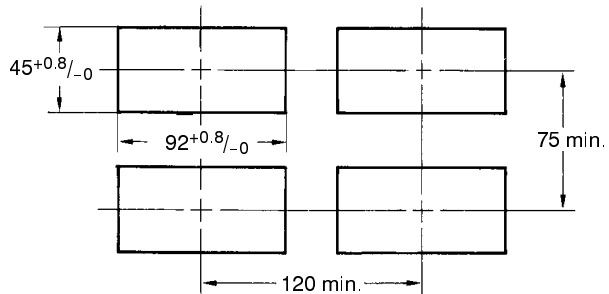

All dimensions are in millimeters.

Note: Attach mounting bracket before wiring the terminals. When removing the Intelligent Signal Processor, first disconnect the wiring, then remove the mounting bracket.

SECTION 5

Input Models

K3TX-□□2□□-□□ (4-digit Series)

There are four K3TX Input Models varying with the type of input (DC voltage input, DC current input, AC voltage input, and AC current input). Each model has multiple input ranges (the input terminals must be selected according to the input range).

DC Voltage Input (K3TX-VD2□□-□□)

Range selection	A	B	C	D	E	F
Connecting terminals (4: Common)	1 to 4		2 to 4		2 to 4	
199.9 V						
99.99 V						
9.999 V						
5.000 V						
1.000 V						
999.9 mV						
99.99 mV						
0 V						
-99.99 mV						
-999.9 mV						
-9.999 V						
-99.99 V						
-199.9 V						

F has a display range of 0.600 to 5.400 V.

DC Current Input (K3TX-AD2□□-□□)

Range selection	A	B	C	D
Connecting terminals (4: Common)	1 to 4		2 to 4	
199.9 mA				
99.99 mA				
20.00 mA				
9.999 mA				
4.00 mA				
0 mA				
-9.999 mA				
-99.99 mA				
-199.9 mA				

D has a display range of 2.40 to 21.60 mA.

AC Voltage Input (K3TX-VA2□□-□□)

Range selection	A	B	C
Connecting terminals (4: Common)	1 to 4		3 to 4
400.0 V			
99.99 V			
9.999 V			
0 V			

A has a display range of 0.0 to 440.0 V.

AC Current Input (K3TX-AA2□□-□□)

Range selection	A	B	C	D
Connecting terminals (4: Common)	1 to 4		2 to 4	
10.00 A				
1.999 A				
199.9 mA				
99.99 mA				
0 mA				

A has a display range of 0.00 to 11.00 A.

K3TX-□□3□A-□□ (4¹/₂-digit Series)

There are K3TX-□□D3□A-□□ models with DC voltage input and those with DC current input, both of which have multiple input ranges. A particular terminal must be used according to the input range.

DC Voltage Input (K3TX-VD3□A-□□)

Range selection	A	B	C	D	E
Connecting terminals (4: Common)	1 to 4	2 to 4		3 to 4	2 to 4
199.99 V					
19.999 V					
5.000 V					
1.9999 V					
1.000 V					
199.99 mV					
0 V					
-199.99 mV					
-1.9999 V					
-19.999 V					
-199.99 V					

E has a display range of 0.600 to 5.400 V.

DC Current Input (K3TX-AD3□A-□□)

Range selection	A	B	C
Connecting terminals (4: Common)	1 to 4	2 to 4	
199.99 mA			
20.00 mA			
19.999 mA			
4.00 mA			
0 mA			
-19.999 mA			
-199.99 mA			

C has a display range of 2.40 to 21.60 mA.

SECTION 6

Parameter Setting and Operation

This section provides instructions for the operation of the K3TX Intelligent Signal Processor. Each operational procedure is described using flow diagrams.

6-1	Before Setting the Parameters	26
6-1-1	Level of Setting Mode and Parameters	26
6-1-2	Parameter Setting Procedure	28
6-1-3	List of Parameters for Each Model	28
6-2	Parameter Setting	30
6-2-1	Input Range	30
6-2-2	Supply Frequency	32
6-2-3	Parameters for Display	33
6-2-4	Parameters for Output	37
6-3	Operations	48
6-3-1	Operations in RUN Mode	48
6-3-2	Special Functions	57

6-1 Before Setting the Parameters

6-1-1 Level of Setting Mode and Parameters

The Intelligent Signal Processor is used mainly in two modes: the RUN mode and the setting mode. In these two modes, the various parameters of the Intelligent Signal Processor can be set. The setting mode has two levels, in each of which one or more parameters can be used. To set the parameters, therefore, first select the setting mode, then select the level and parameter required, from which the necessary parameters can be set. The following diagram illustrates how this can be done.

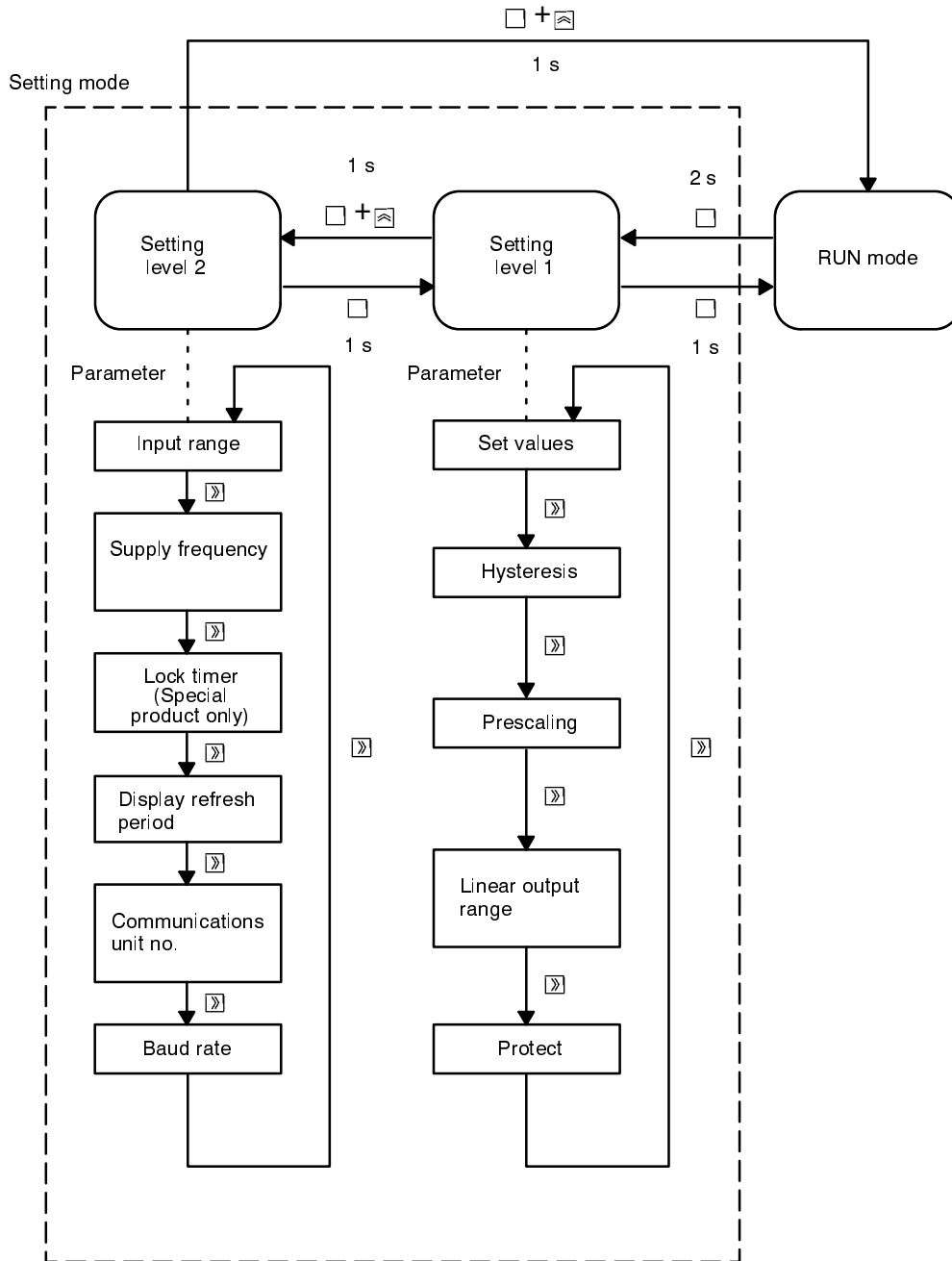

When setting mode is selected, measurement is stopped. Some parameters may not be displayed (i.e., cannot be selected or set), depending on the operating parameter selected and the type of model. For details, refer to the list

of valid parameters by operating parameter see 6-1-3 List of Parameters for Each Model.

During operation, if you are unsure of the present status (such as the level or parameter with which the setting has been made), press the Level Key for one second to go one level lower. Be sure to write the set value again on that level. The following list and accompanying diagrams describe how to set levels in step-by-step fashion.

Setting procedure:

1. Go up the stairs to the level you want (Level Key or Level Key + Up Key).
2. Look for the parameter (Shift Key).
3. Access the parameter (Display Key).
4. Change the number inside (Up or Shift Key).
5. Leave the parameter (Display Key).
6. Go back to RUN mode (Level Key or Level Key + Up Key).

Setting Level Diagram

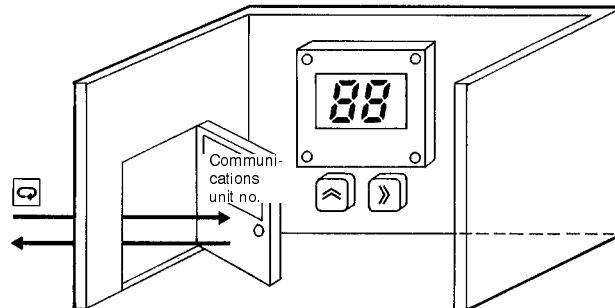
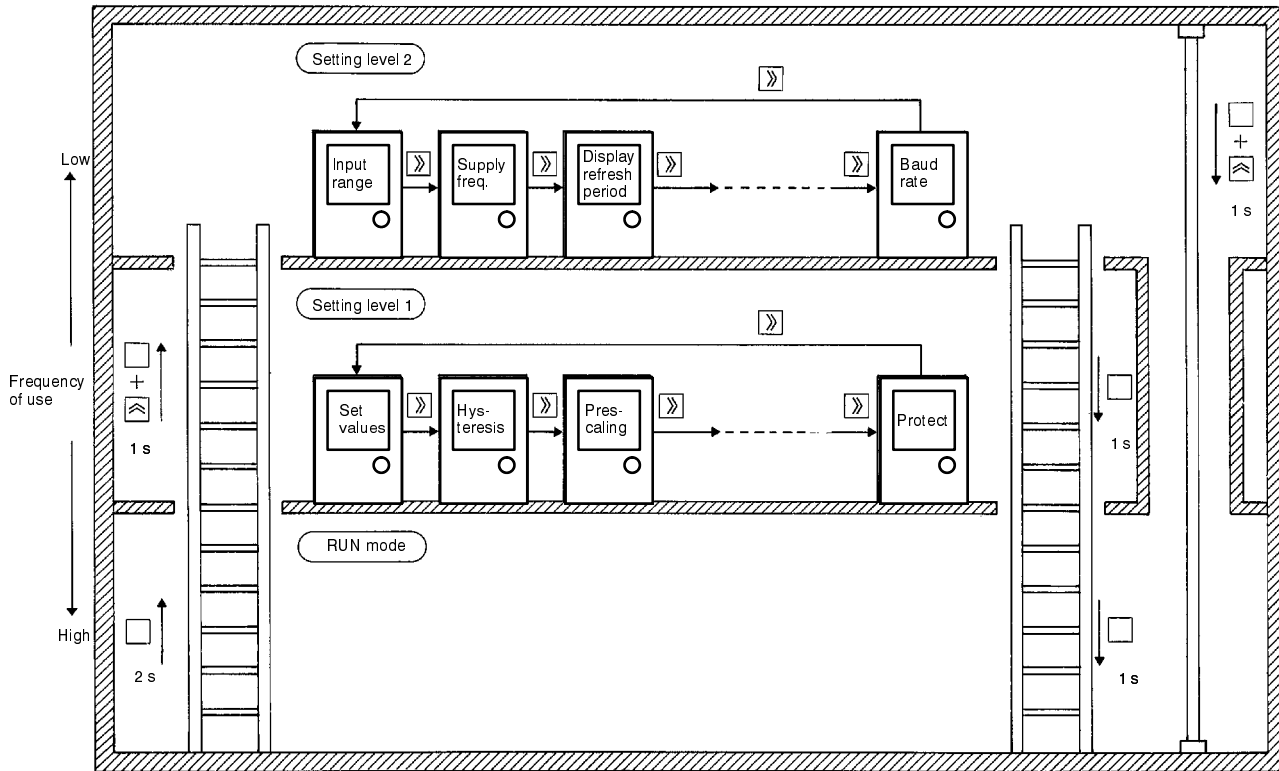

6-1-2 Parameter Setting Procedure

No particular sequence needs to be followed when making parameter settings; however, note the following:

If the setting for input range is changed, the other parameter settings in the parameter are not changed, except in the case of the prescale value. However the decimal point of the set value will change according to the new input range.

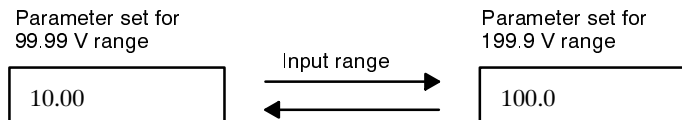

6-1-3 List of Parameters for Each Model

4-digit Series

The following tables indicate which parameters are available for each model.

Basic Models: K3TX-□□2□A-□□

Level	Item	Display	Output										
			None	C1/2/5, T1/2	B2	L1/2	L3	S1/2/3	B4	L4/5	L6	S5/6	
1	Set value	cset	---	Yes	---	---	---	---	---	Yes	Yes	Yes	Yes
	Hysteresis	hys	---	Yes	---	---	---	---	---	Yes	Yes	Yes	Yes
	Prescaling	scal	Yes	Yes	Yes	Yes	Yes	Yes	Yes	Yes	Yes	Yes	Yes
	Linear output range	lset	---	---	---	Yes	---	---	---	Yes	---	---	---
	Set value protect	prot	---	Yes	---	---	---	---	---	Yes	Yes	Yes	Yes
2	Input range	in-t	Yes	Yes	Yes	Yes	Yes	Yes	Yes	Yes	Yes	Yes	Yes
	Supply frequency	s--6	Yes	Yes	Yes	Yes	Yes	Yes	Yes	Yes	Yes	Yes	Yes
	Display refresh period	disp	Yes	Yes	Yes	Yes	Yes	Yes	Yes	Yes	Yes	Yes	Yes
	Communications unit no.	u-no	---	---	---	---	---	---	Yes	---	---	---	Yes
	Baud rate	bps	---	---	---	---	---	---	Yes	---	---	---	Yes

Set Value LED Display Models: K3TX-□□2□B-□□

Level	Item	Display	Output				
			C1/2/5, T1/2	B4	L4/5	L6	S5/6
1	Set value	cset	Yes	Yes	Yes	Yes	Yes
	Hysteresis	hys	Yes	Yes	Yes	Yes	Yes
	Prescaling	scal	Yes	Yes	Yes	Yes	Yes
	Linear output range	lset	---	---	Yes	---	---
	Set value protect	prot	Yes	Yes	Yes	Yes	Yes
2	Input range	in-t	Yes	Yes	Yes	Yes	Yes
	Supply frequency	s--6	Yes	Yes	Yes	Yes	Yes
	Display refresh period	disp	Yes	Yes	Yes	Yes	Yes
	Communications unit no.	u-no	---	---	---	---	Yes
	Baud rate	bps	---	---	---	---	Yes

Thumbwheel Switches Models: K3TX-□□2□D-□□

Level	Item	Display	Output	
			C1/2/5, T1/2	B4
1	Set value	cset	---	---
	Hysteresis	hys	Yes	Yes
	Prescaling	scal	Yes	Yes
	Linear output range	lset	---	---
	Set value protect	prot	---	---
2	Input range	in-t	Yes	Yes
	Supply frequency	s--6	Yes	Yes
	Display refresh period	disp	Yes	Yes
	Communications unit no.	u-no	---	---
	Baud rate	bps	---	---

4¹/₂-digit Series

Basic Models: K3TX-□D3□A-□□ (4¹/₂-digit Series)

Level	Item	Display	Output		
			None	C2,T1	B2
1	Set value	cset	---	Yes	---
	Hysteresis	hys	---	Yes	---
	Prescaling	scal	Yes	Yes	Yes
	Set value protect	prot	---	Yes	---
2	Input range	in-t	Yes	Yes	Yes
	Supply frequency	s--6	Yes	Yes	Yes
	Display refresh period	disp	Yes	Yes	Yes

6-2 Parameter Setting

6-2-1 Input Range

In order to set the input range, follow the instructions outlined in the flow diagram (below the tables) and specify the input range to be used as follows:

K3TX-□□2□□-□□
(4-digit Models)

DC Voltage Input Model		
Display		Range
a Ud	(A VD)	±199.9 V (Setting before shipping)
b Ud	(B VD)	±99.99 V
c Ud	(C VD)	±9.999 V
d Ud	(D VD)	±999.9 mV
e Ud	(E VD)	±99.99 mV
f Ud	(F VD)	1.000 to 5.000 V

DC Current Input Model		
Display		Range
a ad	(A AD)	±199.9 mA (Setting before shipping)
b ad	(B AD)	±99.99 mA
c ad	(C AD)	±9.999 mA
d ad	(D AD)	4.00 to 20.00 mA

AC Voltage Input Model		
Display		Range
a Ua	(A VA)	0 to 400.0 V (Setting before shipping)
b Ua	(B VA)	0 to 99.99 V
c Ua	(C VA)	0 to 9.999 V

AC Current Input Model		
Display		Range
a aa	(A AA)	0 to 10.00 A (Setting before shipping)
b aa	(B AA)	0 to 1.999 A
c aa	(C AA)	0 to 199.99 mA
d aa	(D AA)	0 to 99.99 mA

K3TX-□D3□A-□□
(4¹/₂-digit Models)

DC Voltage Input Model		
Display	Range	
a Ud (A VD)	±199.99 V (Setting before shipping)	
b Ud (B VD)	±19.999 V	
c Ud (C VD)	±1.9999 V	
d Ud (D VD)	±199.99 mV	
e Ud (E VD)	1.000 to 5.000 V	

DC Current Input Model		
Display	Range	
a ad (A AD)	±199.99 mA (Setting before shipping)	
b ad (B AD)	±19.999 mA	
c ad (C AD)	4.00 to 20.00 mA	

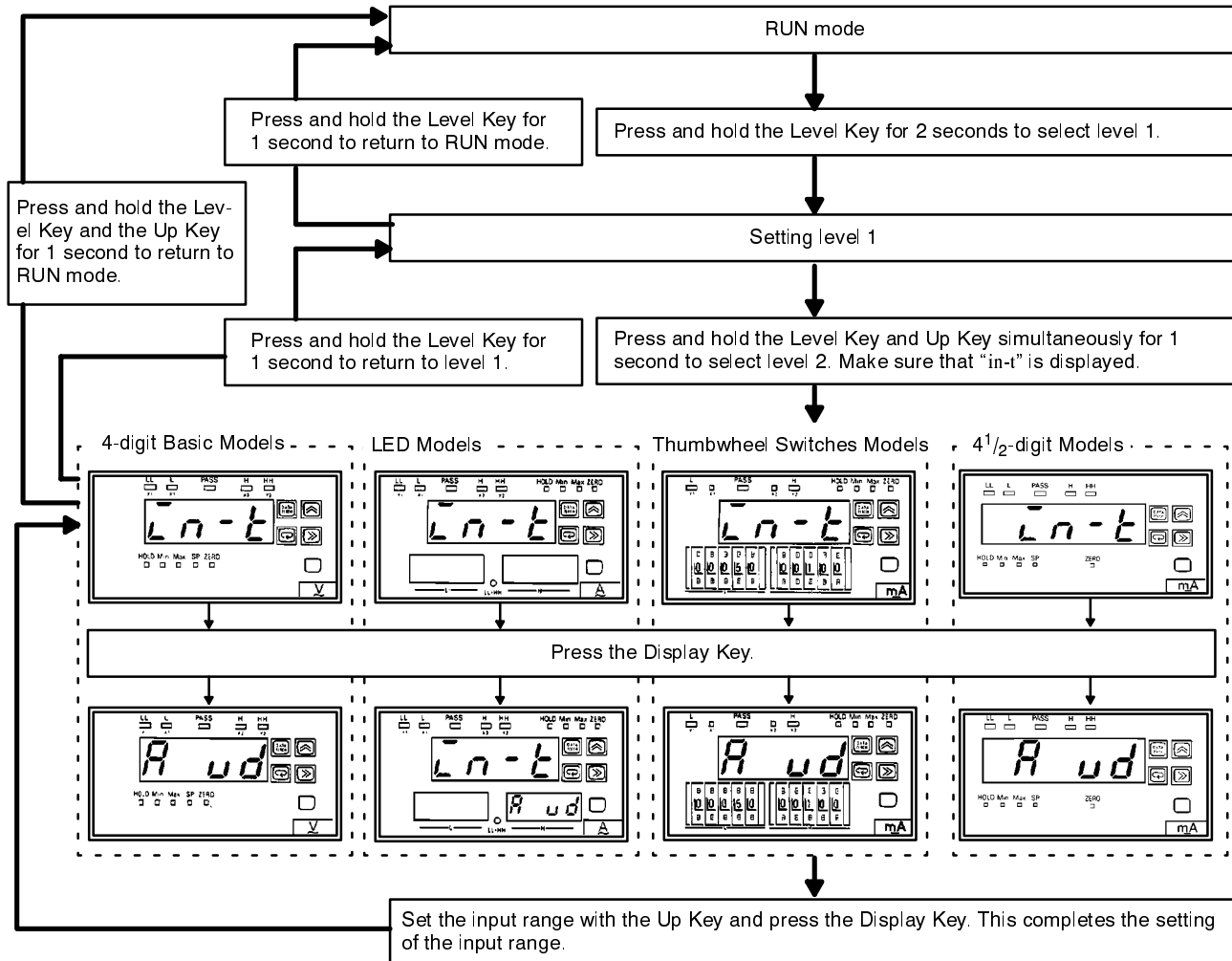

6-2-2 Supply Frequency

The K3TX has two sampling periods. Follow the instructions below to change the selected sampling period in order to remove inductive noise.

Setting	
50	50 Hz (12.5 times/s)
60	60 Hz (15 times/s)

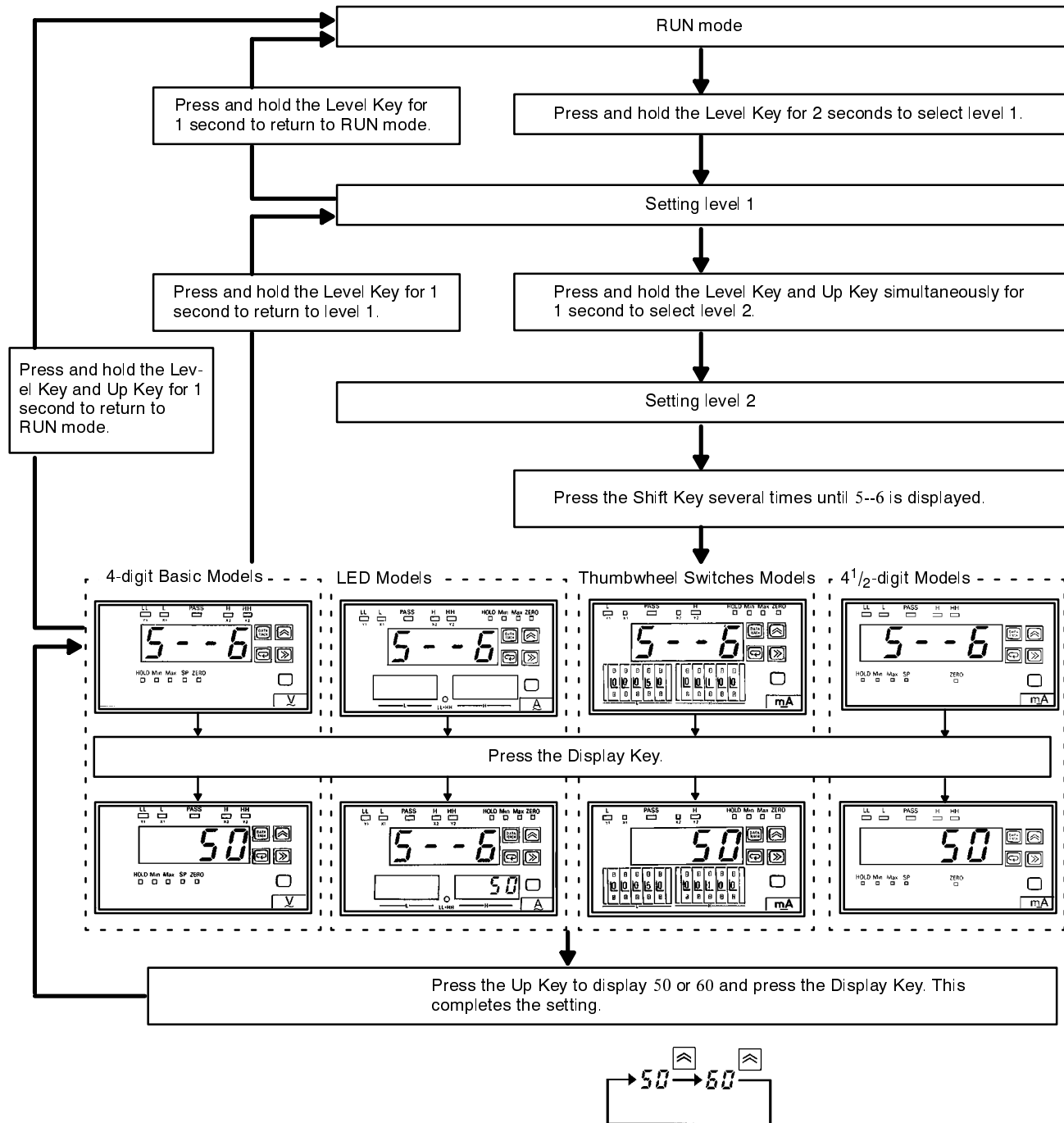

6-2-3 Parameters for Display

Prescaling

Follow the instructions outlined in the flow diagram (following page) to set a prescale value to convert an input value into a desired displayed value.

Model series	Setting range
K3TX-□□2□□-□□	-9999 to 9999
K3TX-□□D3□A-□□	-19999 to 19999

Prescaling Examples

The following examples are graphical representations of the scaling display given a range of prescale values.

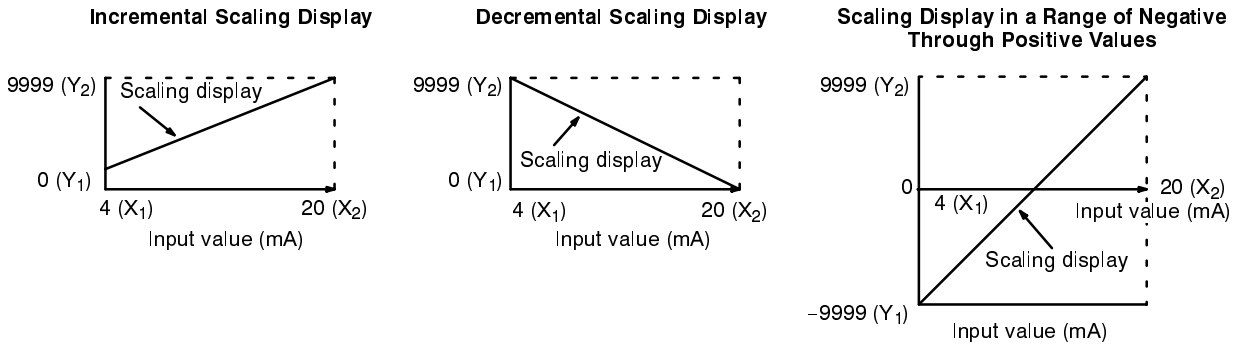

X₁ can be either larger or smaller than X₂. Likewise, Y₁ can be either larger or smaller than Y₂. If X₁ is X₂, it is assumed that X₁ + 1 digit = X₂.

Prescale values can be set in the prescale parameter using the following procedure.

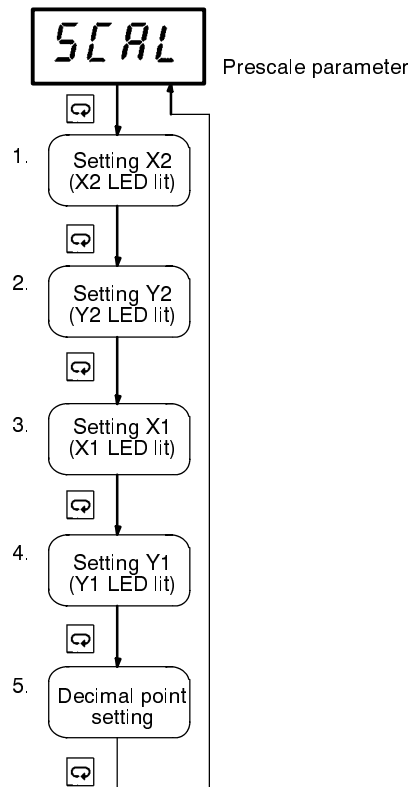
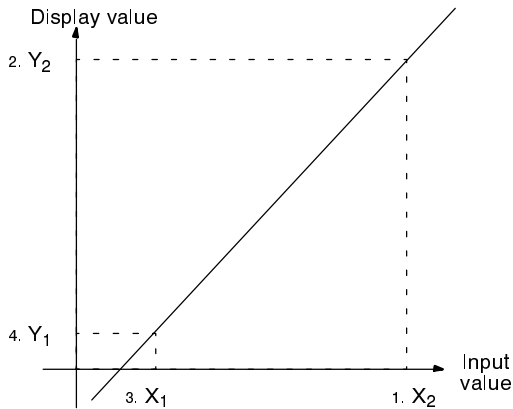

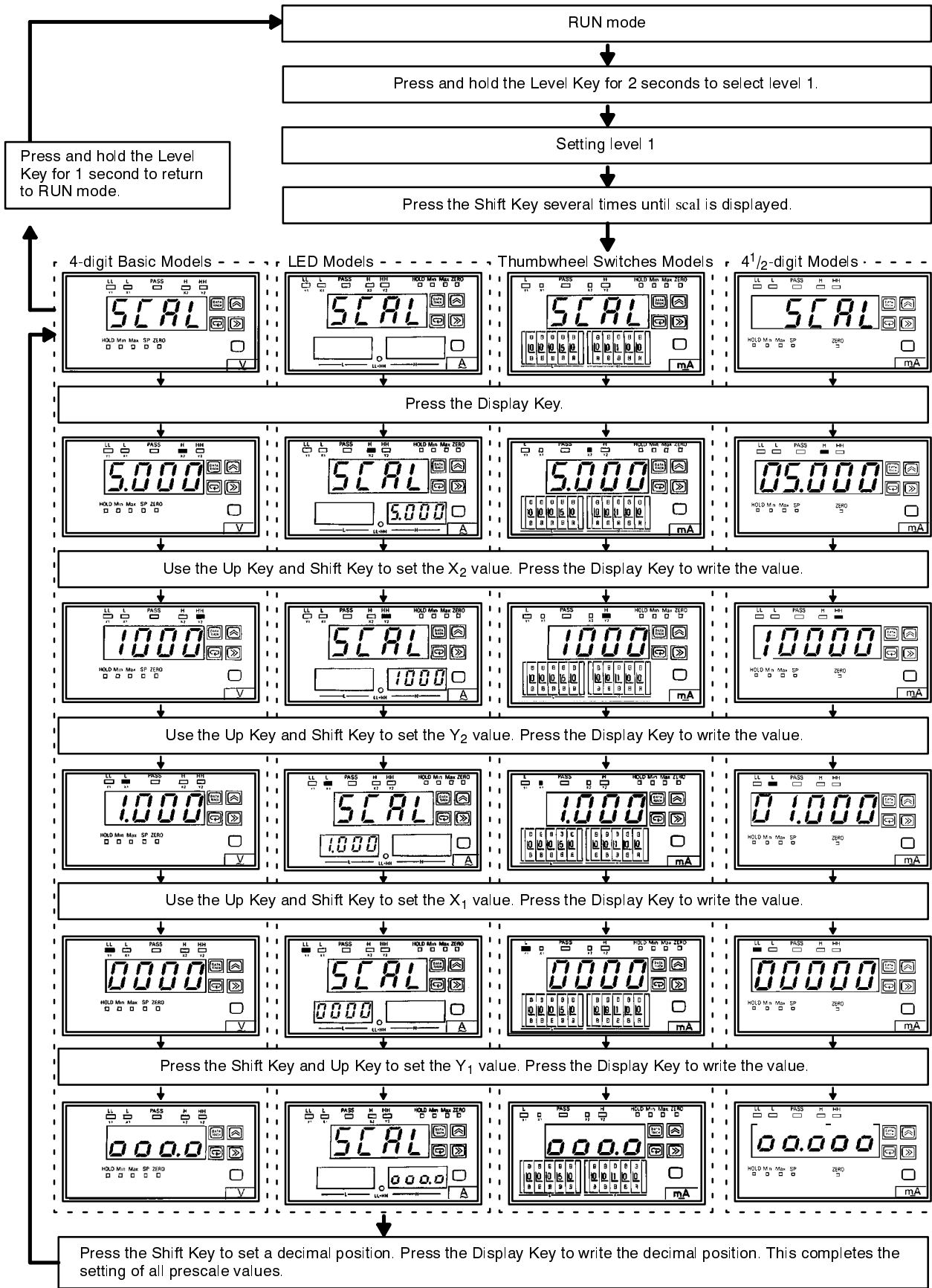

Display Refresh Period

If display data is updated in synchronization with a sampling period, the data may change too rapidly to be read. In this case, the speed at which the displayed data is updated can be slowed down. When a slow data display speed is selected, the sampling period for measurement is not changed. The comparative outputs and BCD output are updated in synchronization with the sampling period.

In order to set the display refresh period, follow the instructions outlined in the flow diagram (after the table) and operate using one of five settings:

Setting range	
fast	Display is updated every sampling period.
1	Display is updated every second.
2	Display is updated every 2 seconds.
3	Display is updated every 3 seconds.
4	Display is updated every 4 seconds.

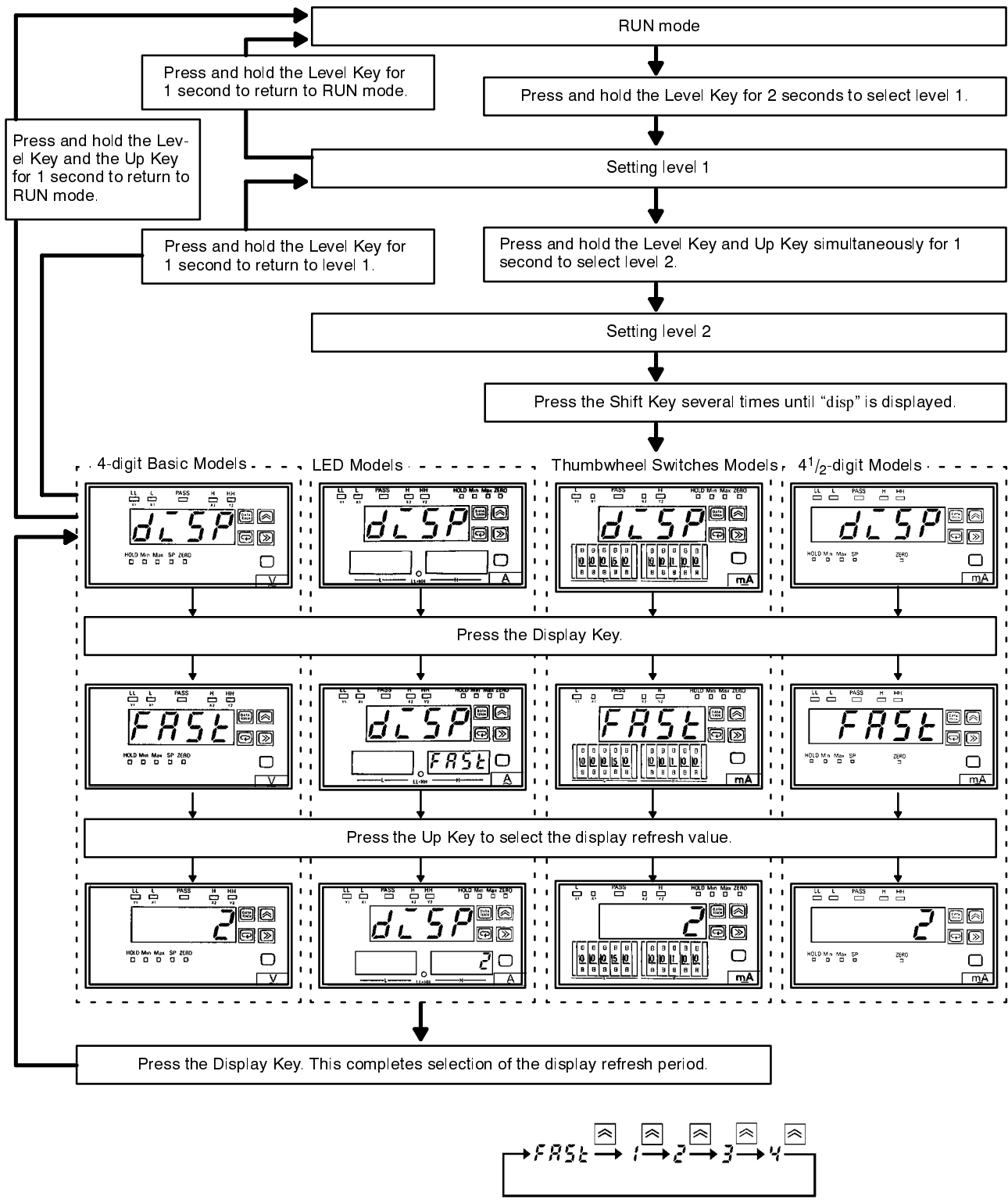

6-2-4 Parameters for Output

Set Values

To establish whether the measured values are within a given range or criteria, they are regularly compared with set values. In order to establish set values, follow the instructions outlined in the flow diagram. The decimal is displayed at the position set in the prescale parameter and in the input range parameter. Also, there is no limitation on the differences in set values among HH, H, L, and LL. On the Thumbwheel Switches Models, the set value parameter is not displayed. In this case, set the set values with the thumbwheel switches on the front panel. If the values are set with the thumbwheel switches, the set values are registered (in 1.5 seconds) and the Intelligent Signal Processor operates according to the new set values. Models provided with only H and L outputs do not allow HH and LL set values to be set.

In order to establish set values, follow the instructions outlined in the flow diagram (after the table) and set within the following range:

Model series	Setting range
K3TX-□□2□□-□□	-9999 to 9999
K3TX-□D3□A-□□	-19999 to 19999

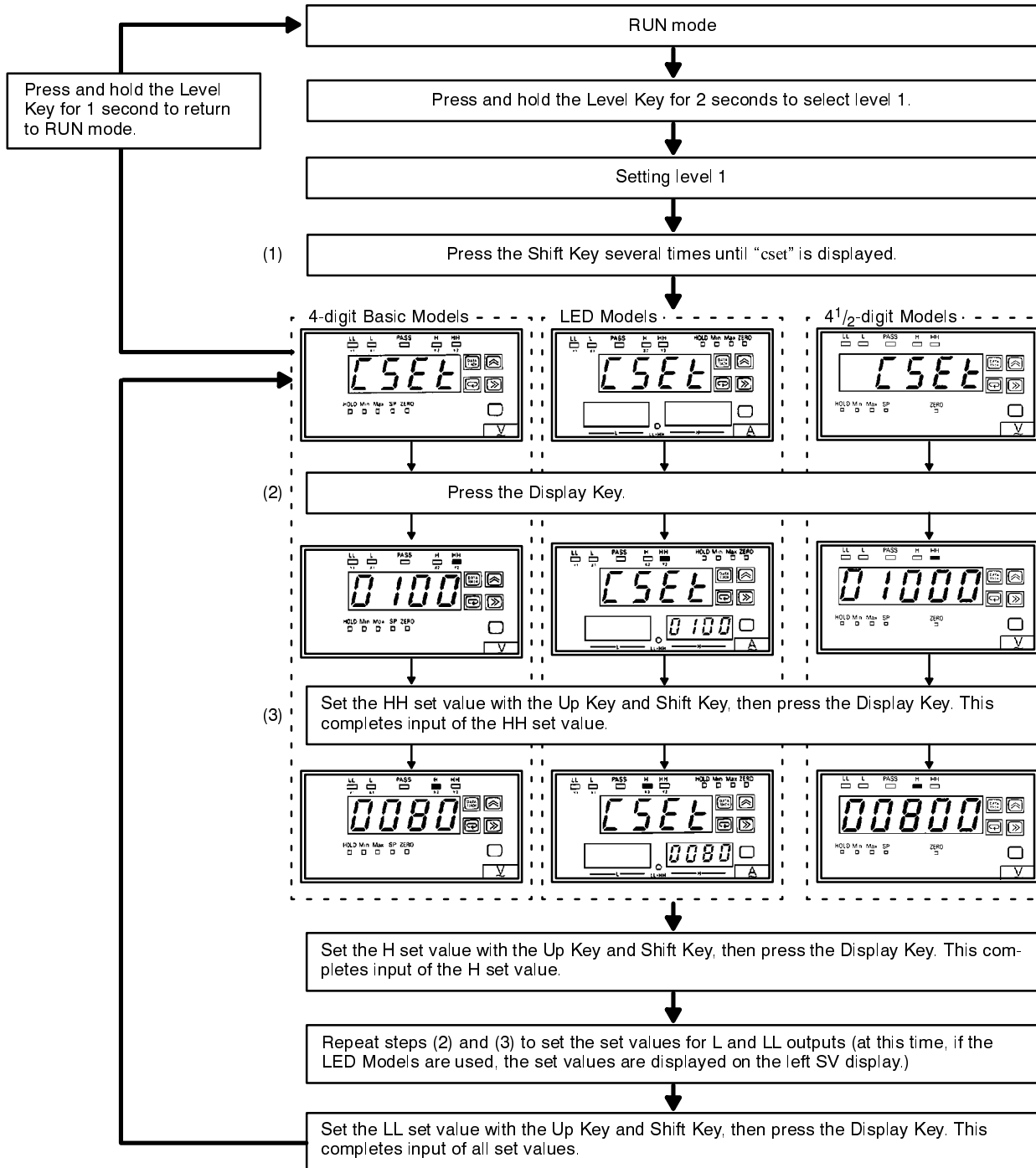

Hysteresis

The established set value includes a hysteresis to prevent the comparative output status from turning ON/OFF when it should not if the measured value (displayed value) fluctuates in the vicinity of the established set value. The hysteresis can be set in a range of 1 to 999 digits (lower 3 digits), and all inputs (HH, H, L, and LL) operate in the same range of hysteresis. In principle, the hysteresis cannot be 0. If set to 0, 1 is assumed. The following graph illustrates the concept of hysteresis.

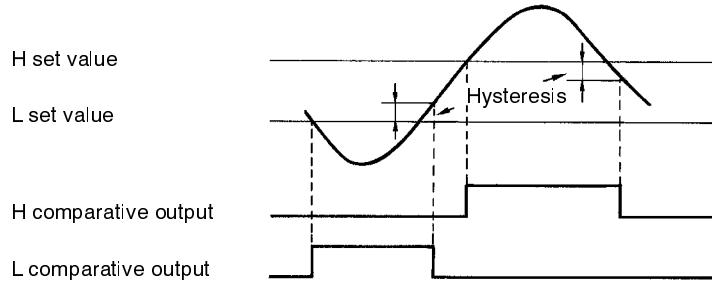

In order to set hysteresis, follow the instructions outlined in the flow diagram (after the table) and set within the following range:

Setting range
001 to 999

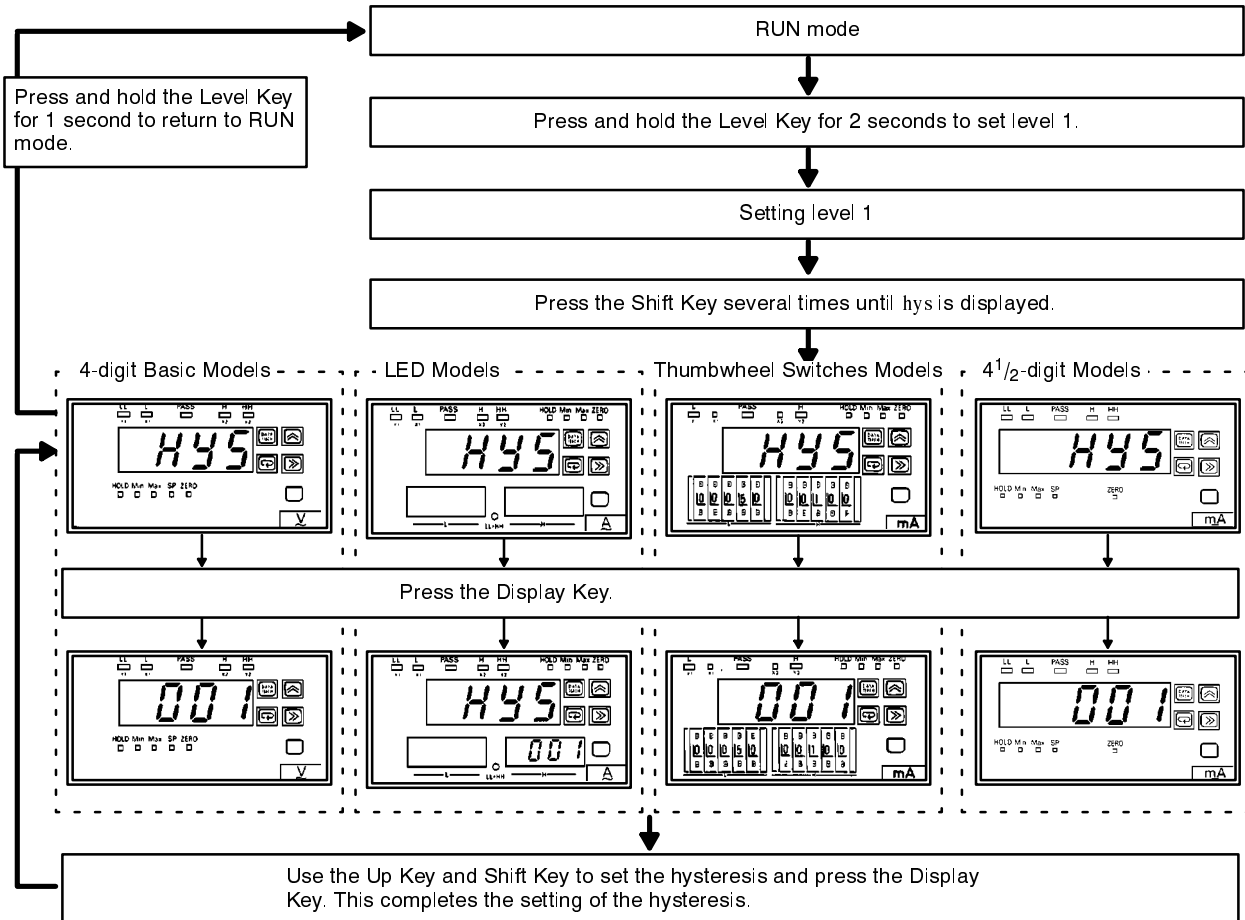

Set Value Protection

With the Basic, LED, and Thumbwheel Switches Models, the set values can be changed in RUN mode. However, the set value will be protected by turning ON the protection function. With the Basic and LED Models, the set values can be protected against changes, even in RUN mode. The Thumbwheel Switches Models are not provided with the protection function; therefore, no protect parameter will be displayed.

In order to protect set values, follow the instructions outlined in the flow diagram (after the table) and operate using one of two settings:

Setting range	Display
Protect ON	on
Protect OFF	off

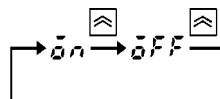
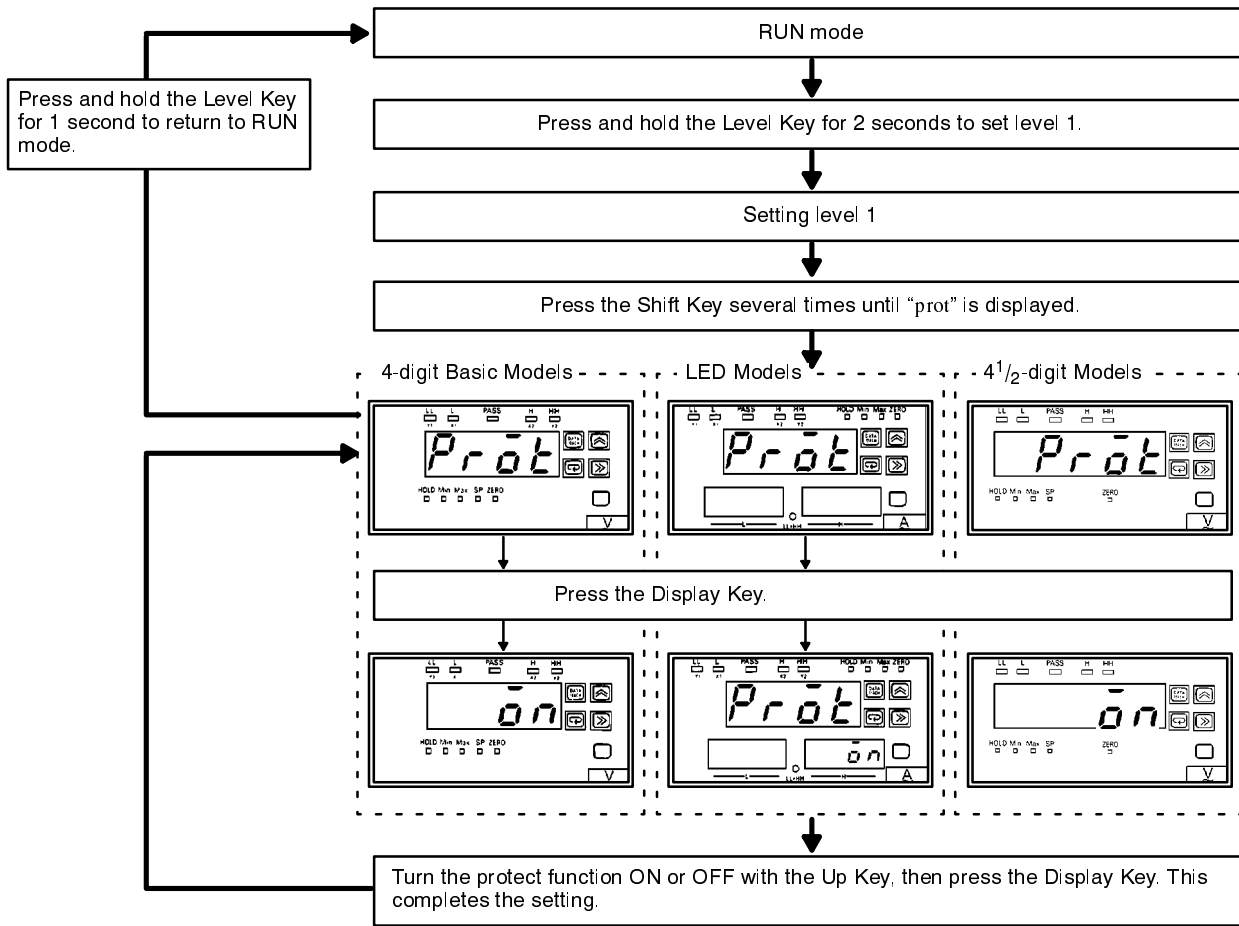

Linear Output Range

This feature is only on the 4 to 20 mA, 1 to 5 V linear output types.

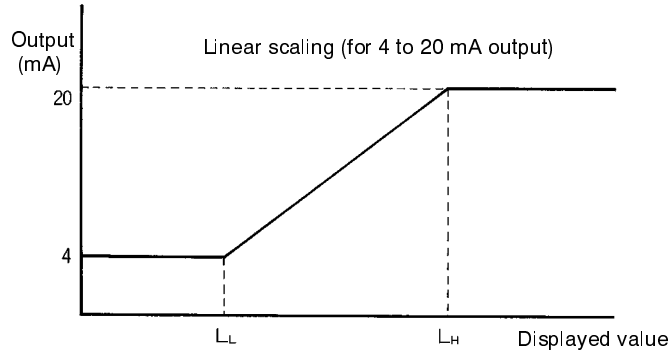

The Intelligent Signal Processor with the 4 to 20 mA, 1 to 5 V linear output, outputs a linear voltage or current in proportion to the changes in the measured value. While the hold function of the maximum and minimum values is effective, the comparative outputs and BCD outputs are output in accordance with changes in the measured value, regardless of the display. To relate the input with the output, displayed value L_H , which corresponds to the maximum output value (20 mA or 5 V), and displayed value L_L , which corresponds to the minimum output value (4 mA or 1 V), should be set as in the above example.

When setting the linear output range, the decimal point is automatically displayed according to the Input Model selected. Do not set $L_L = L_H$; otherwise, it is assumed that $L_L + 1 \text{ digit} = L_H$.

This function is not provided on the mV/digit Output Type. The mV/digit Output Type outputs 1 mVDC per 1 digit of displayed value regardless of the display position of the decimal point (where display value = 150.0, output = 1,500 mVDC).

This function is not provided on the Thumbwheel Switches Models; they do not have the linear output function.

In order to set the linear output range, follow the instructions outlined in the flow diagram and operate the Intelligent Signal Processor as follows:

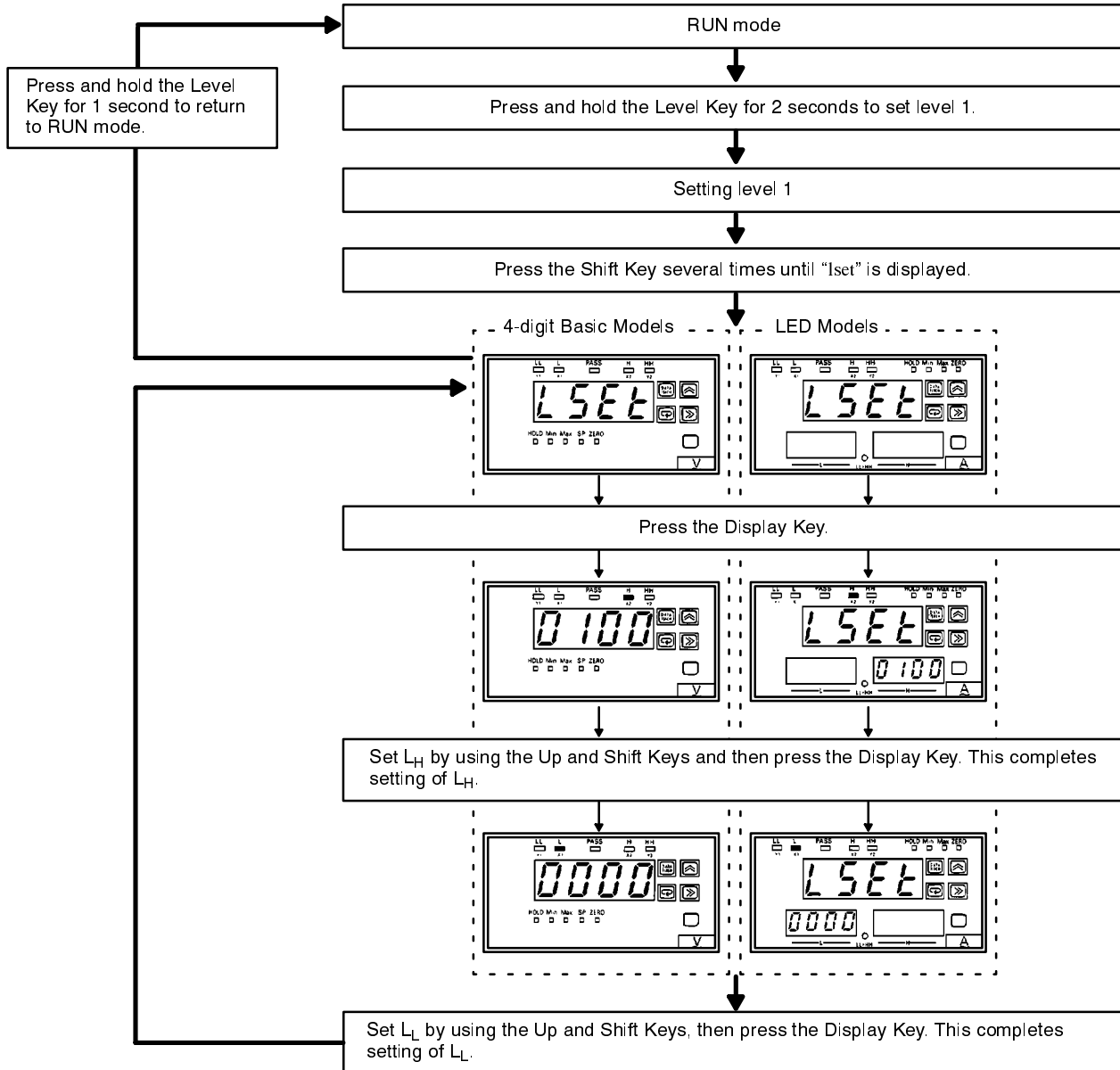

Communications Unit Number

The communications unit number is an identification number by which the host computer to which the Intelligent Signal Processor is connected identifies the Intelligent Signal Processor. The Thumbwheel Switches Models are not provided with the communications output function; therefore, communications unit number setting is not required. A separate manual containing details of the communications specifications is available from OMRON.

In order to set the communications unit number, follow the instructions outlined on the flow diagram (after the table) and set within the following range:

Setting range
00 to 99

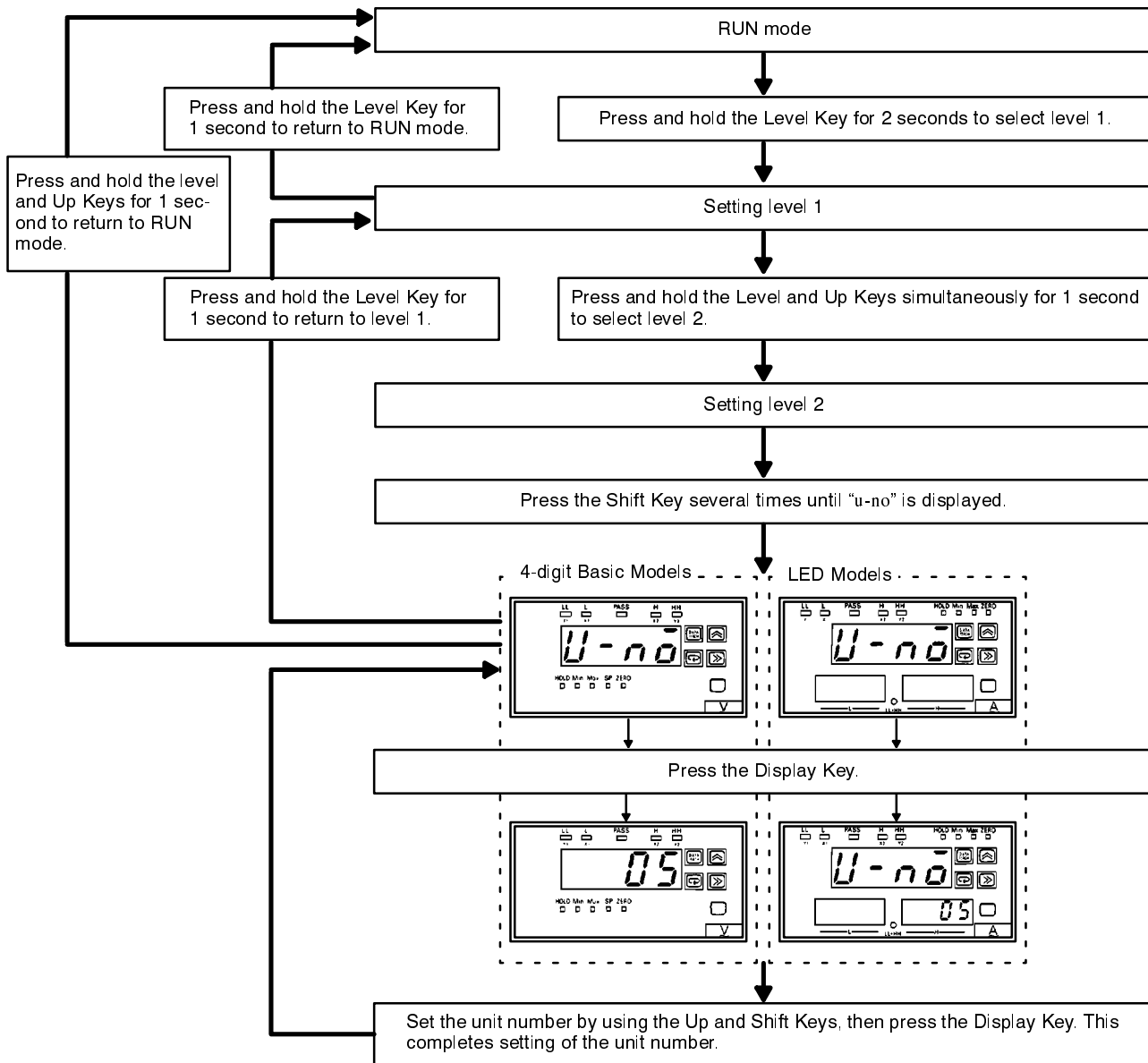

Baud Rate

The Thumbwheel Switches Models are not provided with a communications output function; therefore, setting of the baud rate is not required. For details, refer to the K3TH/K3TR/K3TX Communication Operation Manual.

In order to set the baud rate, follow the instructions outlined in the flow diagram (after the table) and set within the following range:

Setting range	
Display	Meaning
150	150 bps
300	300 bps
600	600 bps
1200	1,200 bps
2400	2,400 bps
4800	4,800 bps
9600	9,600 bps
19.2k	19.2k bps
38.4k	38.4k bps

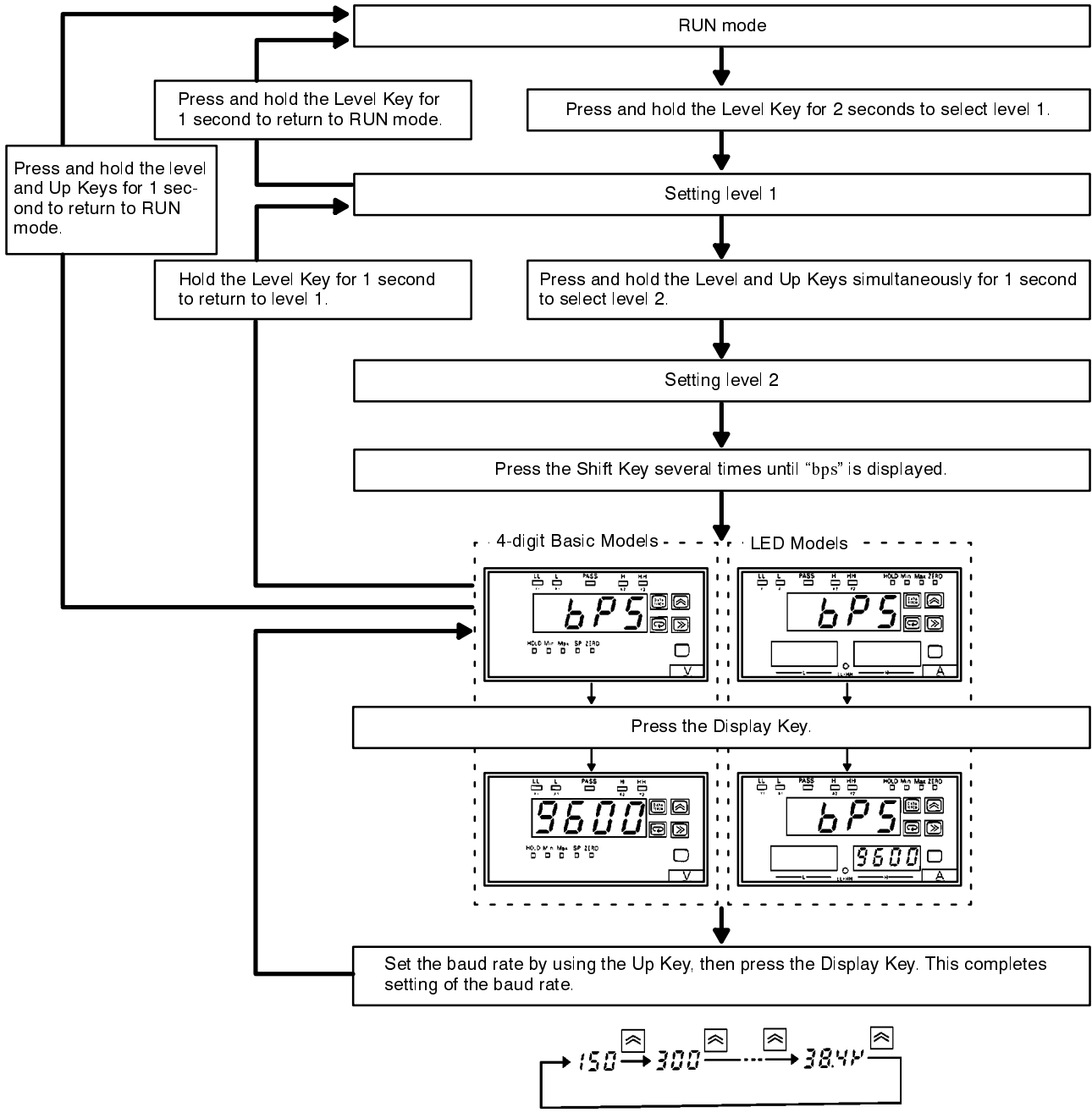

Lock Timer

The lock timer is available only on the K3TX special models.

When the lock input is ON, measurement is interrupted for a specified period during which all outputs are OFF. The operation can be retriggered if desired.

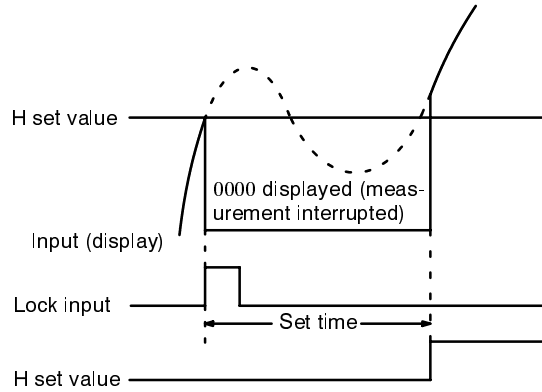

In order to set the lock timer, follow the instructions outlined in the flow diagram (after the table) and set within the following range:

Setting range
0.0 to 99.9 (seconds)

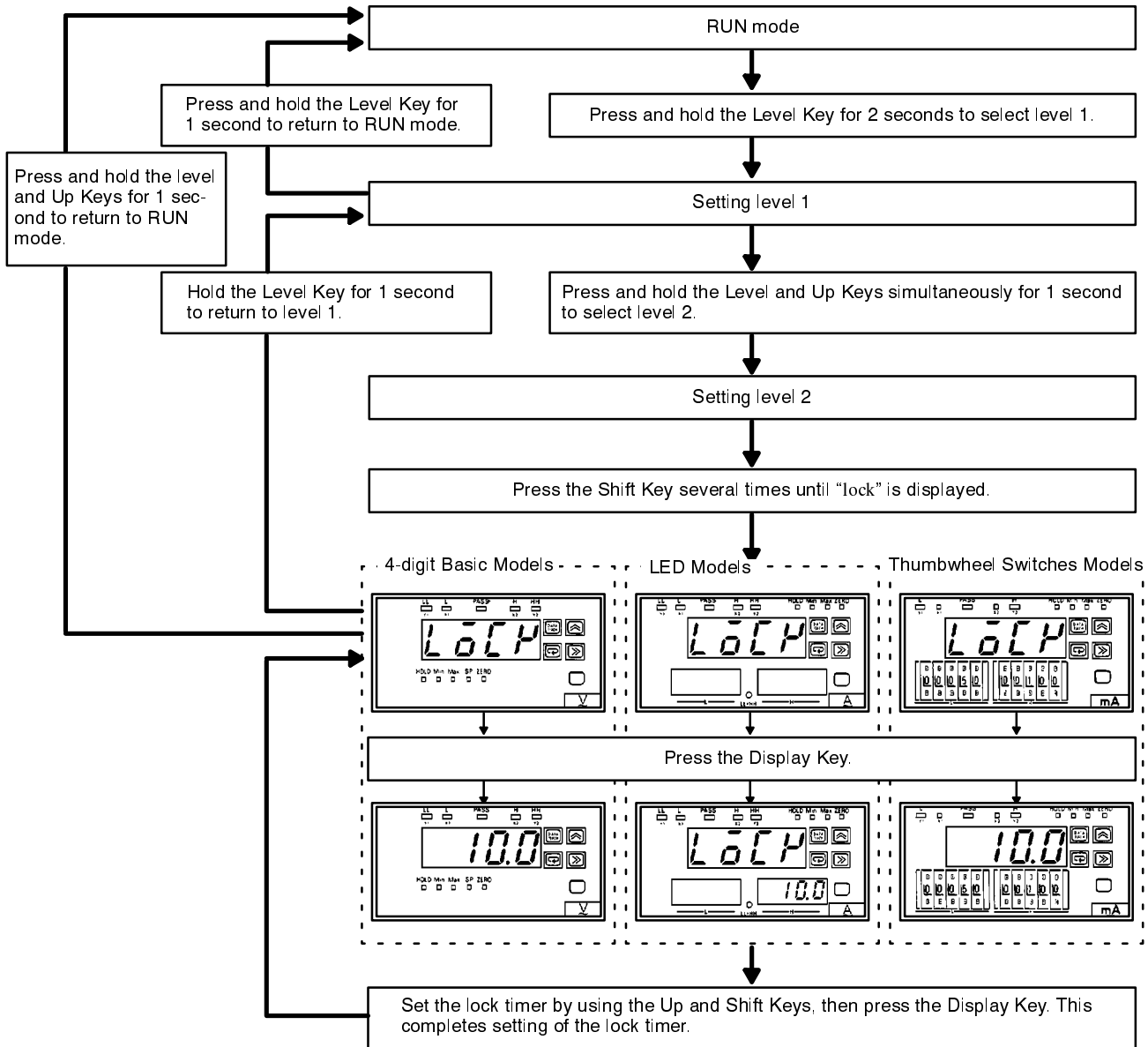

Set Value LED Display Models

Set values LL and HH or L and H are always displayed on the SV display. On models provided with only H and L comparative output status indicators, the set values HH and LL cannot be displayed.

In order to check the set values on the LED Model, follow the instructions outlined in the flow diagram:

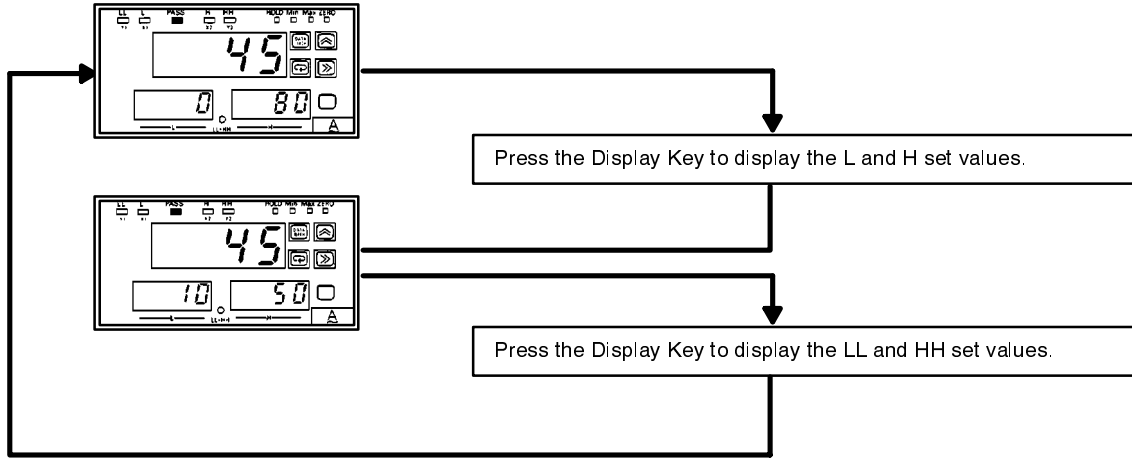

Thumbwheel Switches Models

On the Thumbwheel Switches Models, set values H and L are always displayed.

Changing Set Values

Set values can be changed even in RUN mode except when the set value protect is ON. On models provided with only the H and L comparative output status indicators, the set values HH and LL are not displayed.

Basic Models

When setting the new set value, zero suppress is not effective and the left-most digit of the present set value will start flashing.

In order to change the set values on the Basic Model, follow the instructions outlined in the flow diagram, which shows how to change set value H from 50 to 55:

Set Value Change Procedure

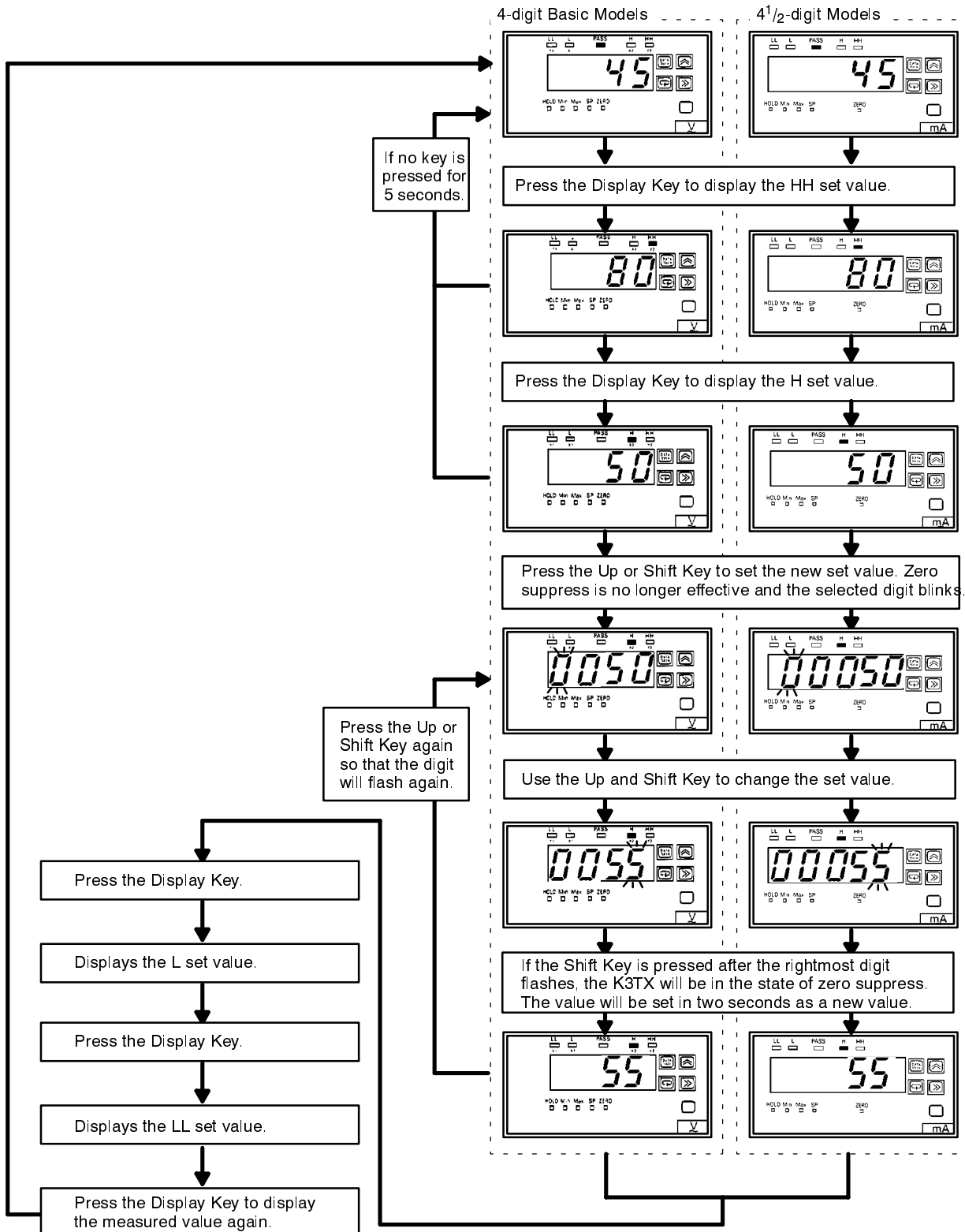

Set Value LED Display Models

In order to change the set values on the Basic Model, follow the instructions outlined on the flow diagram, which shows how to change set value H from 50 to 55:

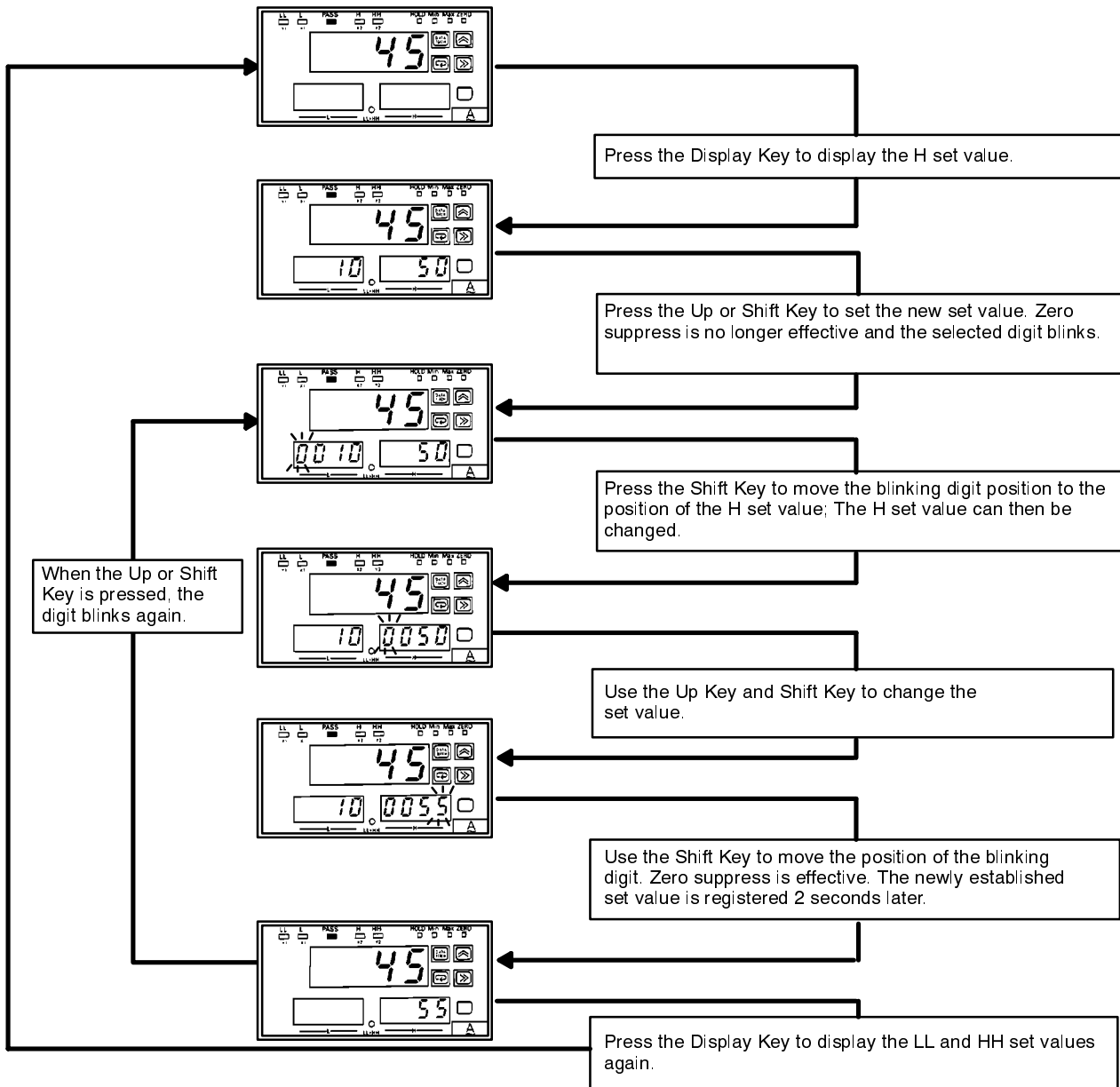

Thumbwheel Switches Models

With the Thumbwheel Switches Models, set values can be changed at any time with the thumbwheel switches. The set values are registered 1.5 seconds after the values have been set with the thumbwheel switches and the Intelligent Signal Processor operates according to the new set values.

Retaining, Resetting Maximum/Minimum Values

The maximum and minimum of the values measured since power application or RESET signal input up to the present point are retained. Each time the DATA TEACH key is pressed, the maximum value, minimum value, and process value are displayed on the PV display in this order. Maximum and minimum data are reset to the process value under one of the following conditions: when the RESET input is ON, when power is OFF, or in setting mode. While the hold function of the maximum and minimum values is effective, the comparative outputs and BCD outputs are output in accordance with changes in the measured value, regardless of the display. The following graph illustrates the effect of this operation.

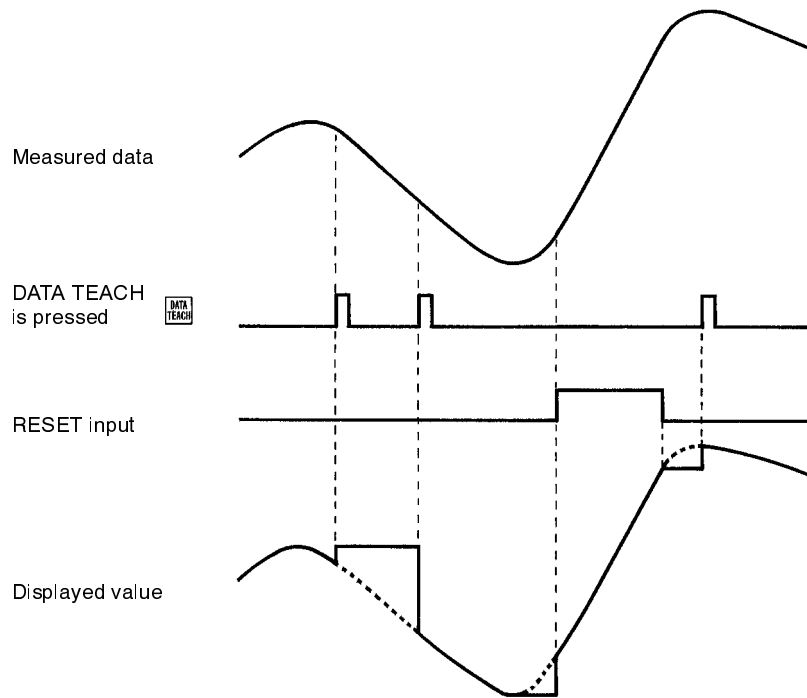

In order to perform this operation, follow the instructions outlined in the flow diagram:

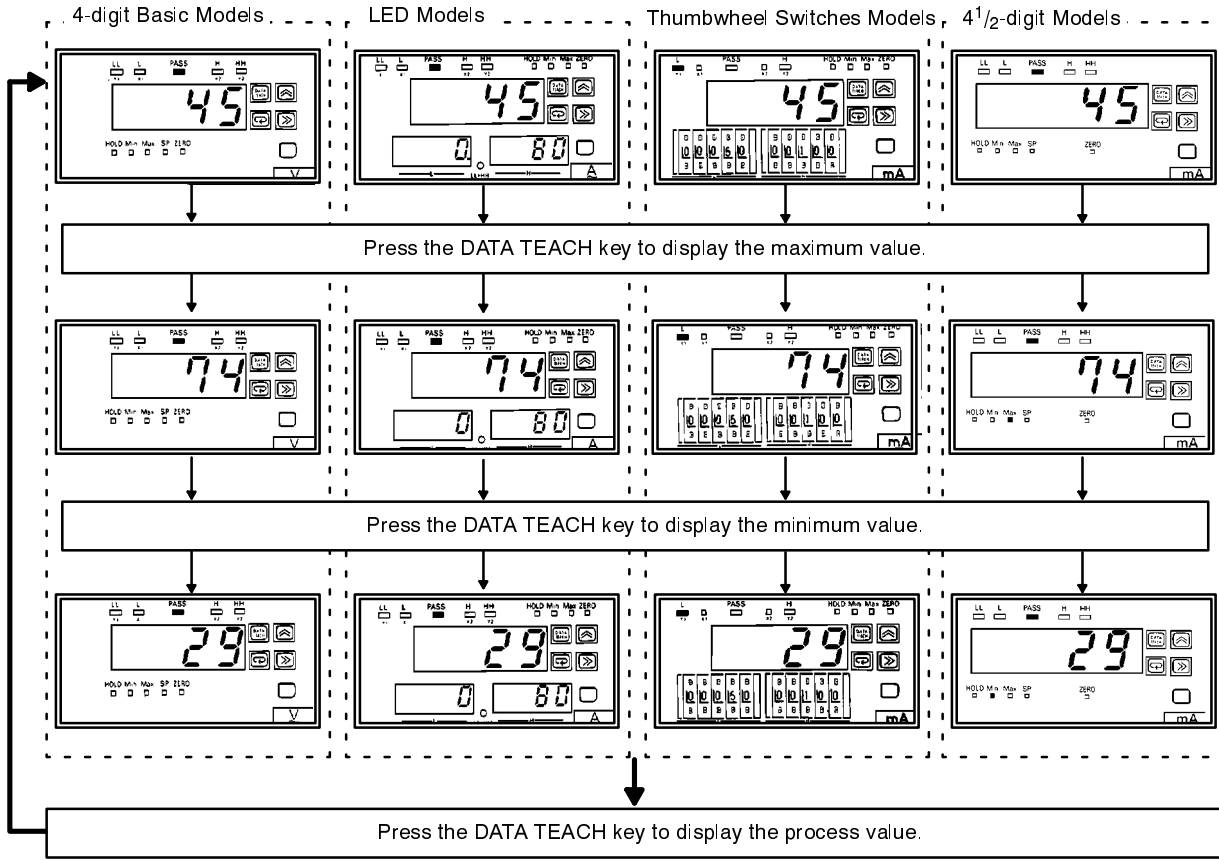

Hold Measured Value

When the HOLD input is turned ON, measurement stops and the input measured just before the HOLD input turned ON is held. The displayed value, comparative outputs, and BCD data are also held. When the HOLD input is turned OFF, the held data is released. If you change set values while the K3TX is holding the measured value, the comparison outputs will change according to the new set value. If power is switched ON while the HOLD input is ON, the K3TX holds 0 as the input value. In this case, 0 is displayed. Make sure the HOLD input is OFF before applying power. The following graph illustrates the effect of this operation.

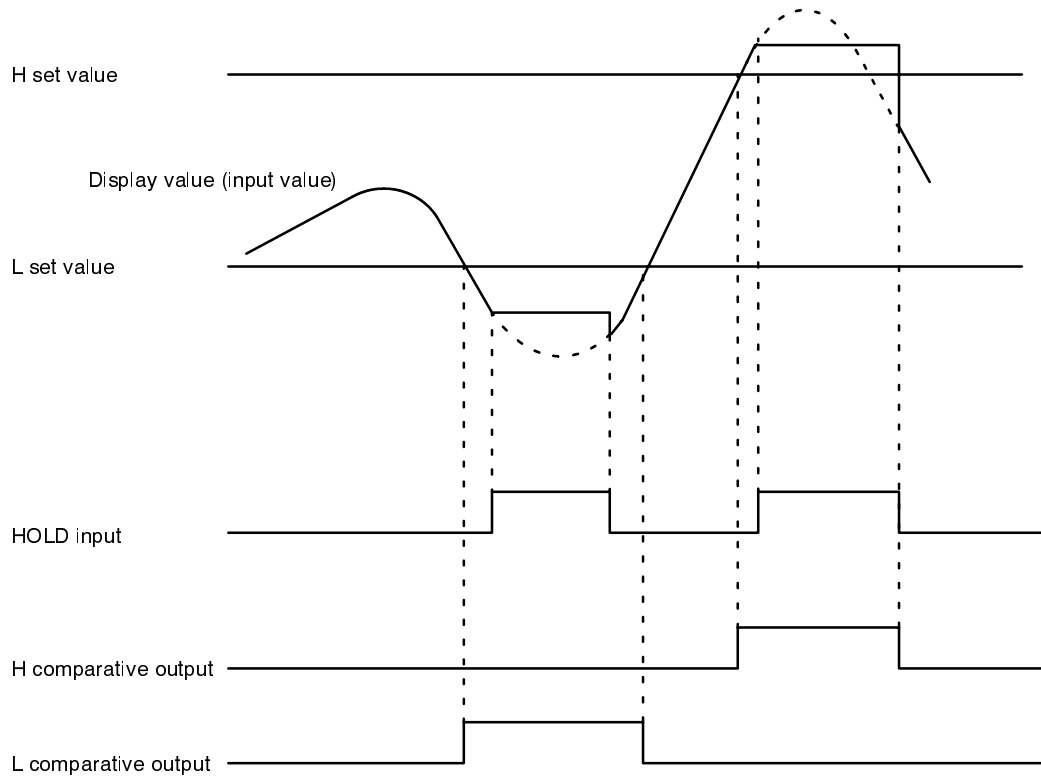

Forced Zero (Zero-shift)

With the ZERO input ON (by short-circuiting the ZERO input), the process value can be shifted to zero. This condition is held until the next ZERO input signal is turned ON. The K3TX retains the zero-shifted value even if power is switched off. To cancel zero-shift state, change the prescaling value.

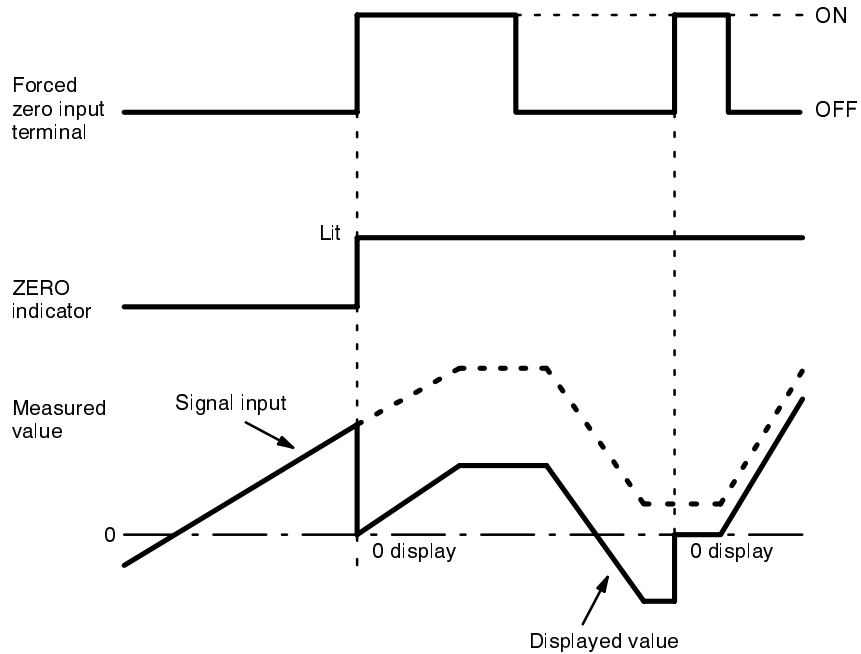

Lock Timer

The lock timer is available only on the K3TX special models.

Measurement is interrupted for a preset period after the lock input is ON. While the lock input is ON, 0000 is displayed. The lock timer is effective from the rising edge of the lock input for a preset period.

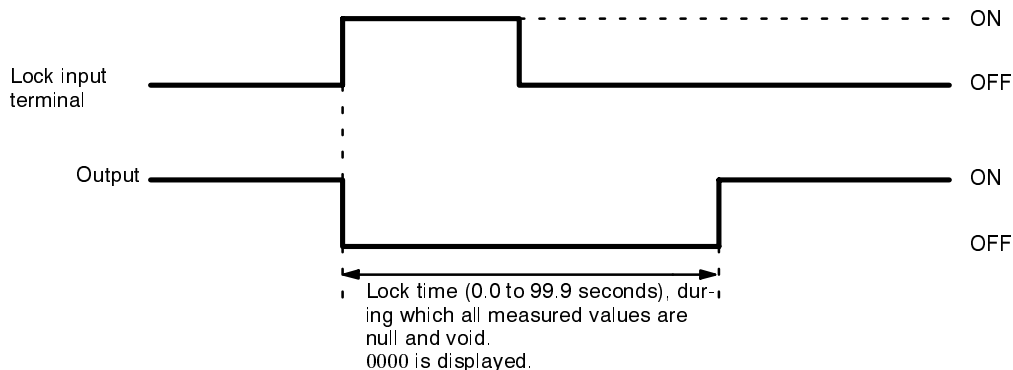

If there is a new lock input while the lock timer is being set, the counter will be reset and the counter will restart after this new lock input is ON.

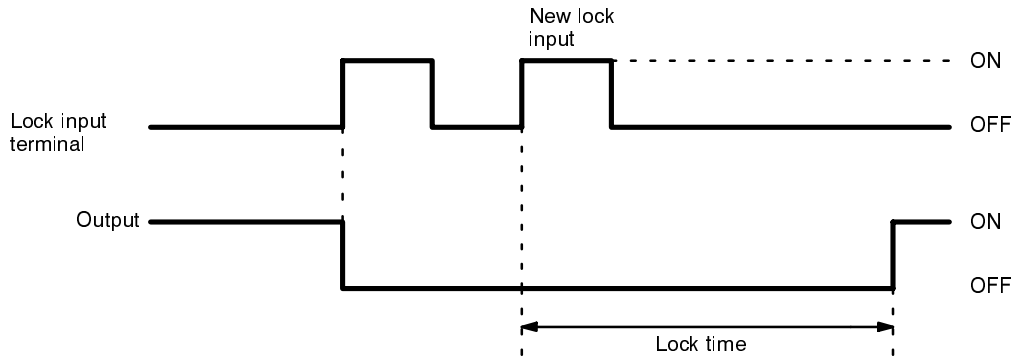

6-3-2 Special Functions

The K3TX Intelligent Signal Processor is provided with two special functions: test mode and teaching function.

1. Test function: This function is convenient for checking a system to which the Intelligent Signal Processor is connected, especially when some inputs cannot be operated. The Intelligent Signal Processor simulates the input, changing the display and output conditions.
2. Teaching function: This function allows the measured values to be set as set values, prescaling values or linear output range while actual measurement is being carried out. This function is useful for setting parameters while checking the operating status of the Intelligent Signal Processor.

Test Function

The Intelligent Signal Processor is provided with a test function in which simulated signals can be input. When a simulated input signal is applied, an actual corresponding output signal is issued. Confirm the status of the equipment connected to the output unit of the Intelligent Signal Processor.

In order to perform this operation, follow the instructions outlined in the flow diagram:

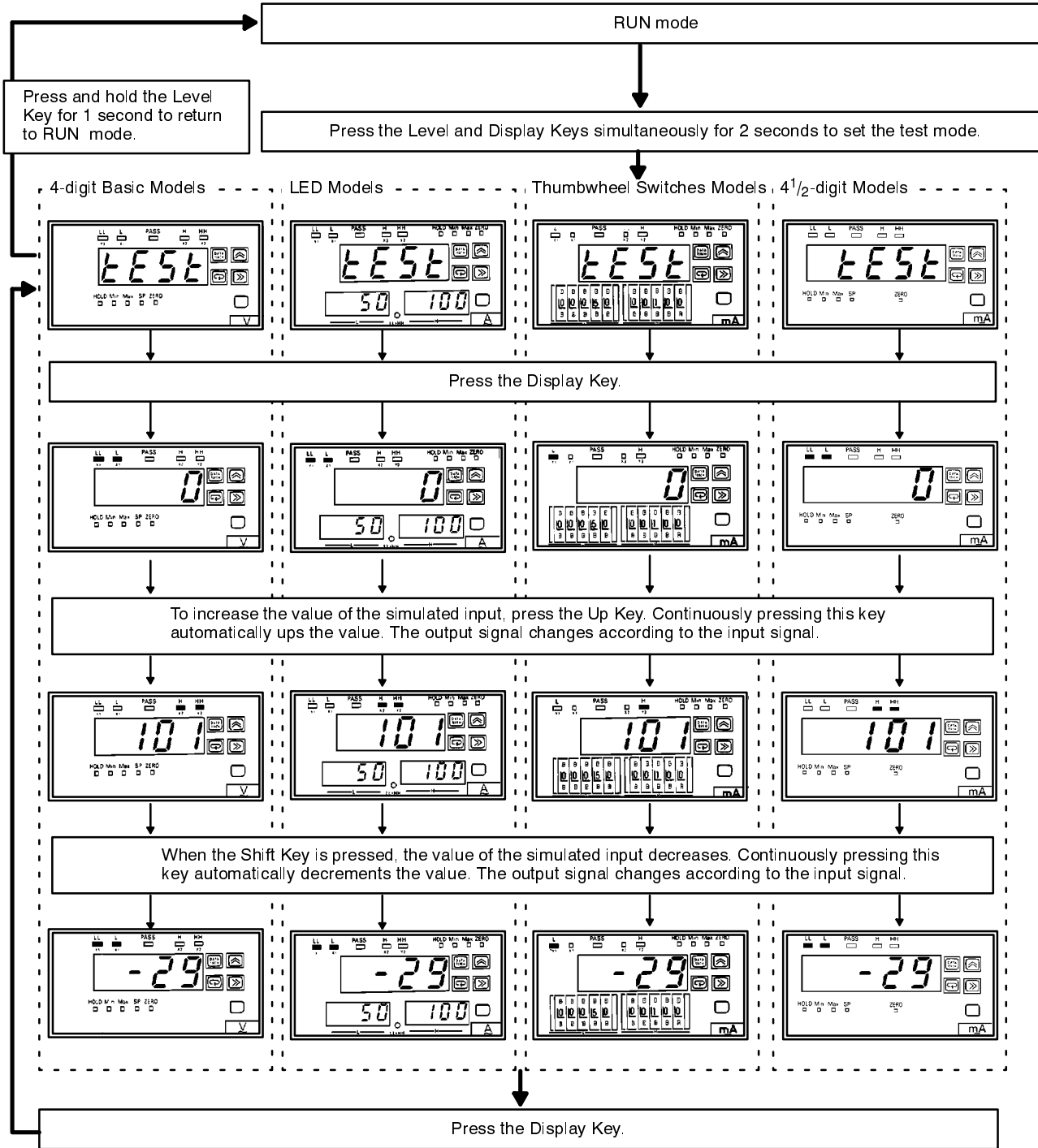

Teaching Function

The Intelligent Signal Processor is provided with a teaching function that can set an actual measured value as a set value, prescaling input value or linear output range.

4-digit Basic Models: Teaching with the actual input of the set value, prescaling input value, and linear output range.

LED Models: Teaching with the actual input of the set value and prescaling input value.

Thumbwheel Switches Models: Teaching with the actual input of the prescaling input value.

4 1/2-digit Basic Models: Teaching with the actual input of the set value and prescaling input value.

- When setting prescaling input values such as X_2 and X_1 , use the DATA TEACH Key to input the actual measured values as prescaling input values

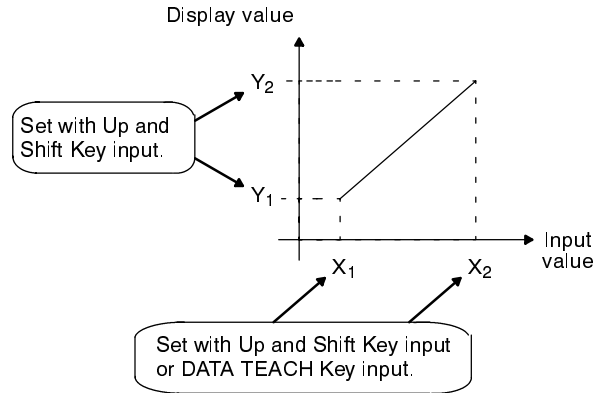

- When setting linear output range, use the DATA TEACH Key and set the actual measured values as maximum (L_H) and minimum (L_L) values in linear output range.

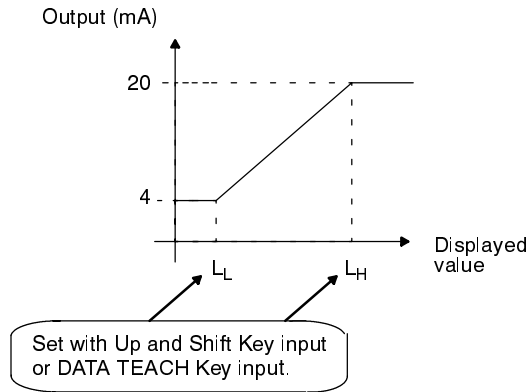

Example of Set Value Setting with Teach Function

In order to perform this operation, follow the instructions outlined in the flow diagram, which shows how to change set value HH from 100 to 102:

The Thumbwheel Switches Models are not provided with this function.

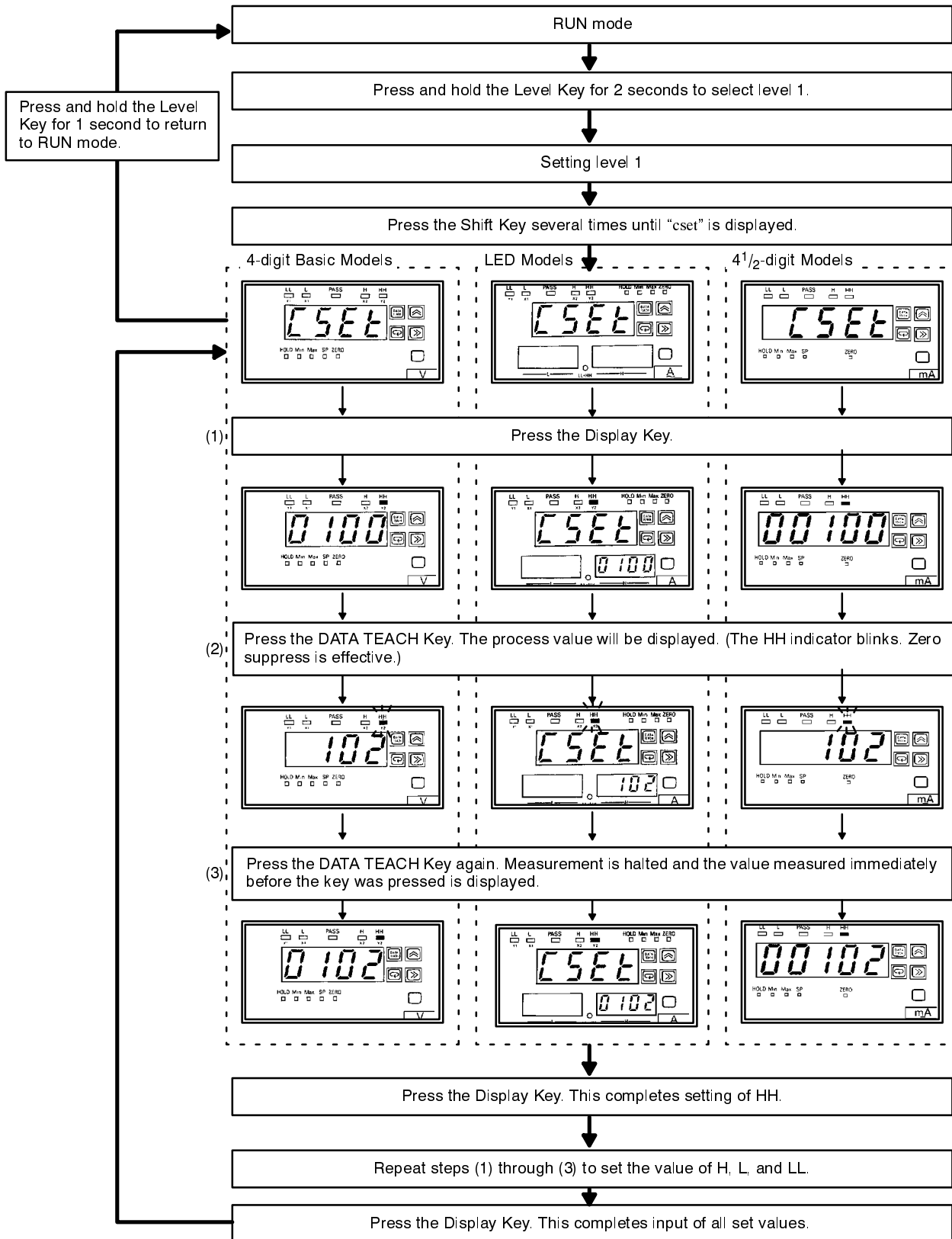

SECTION 7

Troubleshooting

If an error message appears while using the K3TX Intelligent Signal Processor, the problem may originate from either the incorrect use of the Intelligent Signal Processor or a device failure. This troubleshooting section suggests some possible sources of error and the corrective action to be taken.

Troubleshooting Guide	62
-----------------------------	----

Troubleshooting Guide

The following table shows possible errors during the K3TX Intelligent Signal Processor operation and corrective actions to be taken.

Item	Condition	Error message	Output status				Corrective action
			Comparative outputs	BCD output	Linear output	Communications	
Device failure	CPU RAM error, external memory error, memory data error.	eror	OFF	OFF	OFF	OFF	Turn the power OFF and then ON again, once. If the error persists, contact OMRON.
	Corrupted data.	cg-s	OFF	OFF	OFF	OFF	Turn the power OFF and then ON again, once. If the error persists, press the Display Key and set all parameters again.
Overflow, underflow	Input value or display value outside range.	Blinks	Continues	Continues OVER ON	Continues	Continues OVER ON or UNDER ON	Keep the input value and display value within the range.
Output Model change	When Output Model has changed.	cg-o	OFF	OFF	OFF	OFF	Check the Output Model type. If correct, press the Display Key. At this time, the parameters are initialized; therefore, set the parameters again. If the error persists, contact OMRON.
Output Model error	Output Model other than specified.	er-o	OFF	OFF	OFF	OFF	Turn the power OFF and then ON again once. If the error persists, contact OMRON.
Input specification error	Input Model other than specified.	er-i	OFF	OFF	OFF	OFF	Turn the power OFF and then ON again, once. If the error persists, contact OMRON.

Appendix A

Standard Models

The K3TX Intelligent Signal Processor is suited to essentially any application. The following lists the standard models available:

K3TX - -
 1 2 3 4 5 6 7

1, 2: Input Sensors Codes

VD: DC voltage inputs

AD: DC current inputs

VA: AC voltage inputs (excluding 4 1/2-digit Models)

AA: AC current inputs (excluding 4 1/2-digit Models)

3: Series number

2: 4-digit Models

3: 4 1/2-digit Models

4: Power supply voltage

1: 100 to 240 VAC

2: 12 to 48 VDC

3: 48 to 110 VDC (excluding 4 1/2-digit Models)

5: Type of display

A: Basic

B: Set value LED display
(excluding 4 1/2-digit Models)

D: Thumbwheel switches
(excluding 4 1/2-digit Models)

6, 7: Output Type Codes

C1: 3 comparative relay contact outputs (H, PASS, L: SPDT)

C2: 5 comparative relay contact outputs (HH, H, L, LL: SPST-NO; PASS: SPDT)

C5: 5 comparative relay contact outputs (HH, H, L, LL: SPST-NC; PASS: SPDT)

T1: 5 comparative transistor outputs (NPN open collector)*

T2: 5 comparative transistor outputs (PNP open collector)*

B2: BCD output (NPN open collector)**

B4: BCD output + 5 transistor outputs (NPN open collector)*
(special specifications)

L1: Linear output (4 to 20 mA)**

L2: Linear output (1 to 5 VDC)**

L3: Linear output (1 mV/digit)**

L4: Linear output, 4 to 20 mA + 5 transistor outputs (NPN open collector) (special specifications)

L5: Linear output, 1 to 5 V + 5 transistor outputs (NPN open collector) (special specifications)

L6: Linear output, 1 mV/digit+ 5 transistor outputs (NPN open collector) (special specifications)

L7: 0 to 5 VDC (special specifications)

L8: 0 to 10 VDC (special specifications)

L9: 0 to 5 VDC + 5 transistor outputs (NPN open collector) (special specifications)

L10: 0 to 10 VDC + 5 transistor outputs (NPN open collector) (special specifications)

S1: Communication RS-232C**

S2: Communication RS-485**

S3: Communication RS-422**

S5: RS-485 + 5 transistor outputs (NPN open collector) (special specifications)

S6: RS-422 + 5 transistor outputs (NPN open collector) (special specifications)



Note

Refer to the *Output Board Combinations* table on pages 64 and 65.

*Only H, PASS, and L outputs are available as transistor outputs on Thumbwheel Switches Models.

**These output types are available on Basic Models only.

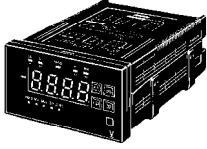
Base Unit (4-digit Models)

Model	Input type	Supply voltage		
		100 to 240 VAC	12 to 24 VDC	48 to 110 VDC
Basic Models These models provide a present value LED and front-panel control keys. Can be connected to any Output Board, or can be used for display only without an Output Board. 	DC voltage	K3TX-VD21A	K3TX-VD22A	K3TX-VD23A
	DC current	K3TX-AD21A	K3TX-AD22A	K3TX-AD23A
	AC voltage	K3TX-VA21A	K3TX-VA22A	K3TX-VA23A
	AC current	K3TX-AA21A	K3TX-AA22A	K3TX-AA23A
Set Value LED Models These models provide a present value LED, set value LED, and front-panel control keys. Can be connected to Relay, Transistor, or Combination Output Boards. 	DC voltage	K3TX-VD21B	K3TX-VD22B	K3TX-VD23B
	DC current	K3TX-AD21B	K3TX-AD22B	K3TX-AD23B
	AC voltage	K3TX-VA21B	K3TX-VA22B	K3TX-VA23B
	AC current	K3TX-AA21B	K3TX-AA22B	K3TX-AA23B
Thumbwheel Switches Models These models provide a present value LED, thumbwheel switches for the set value, and front-panel control keys. Can be connected to K31-C1, K31-T1, K31-T2, and K31-B4 Output Boards. 	DC voltage	K3TX-VD21D	K3TX-VD22D	K3TX-VD23D
	DC current	K3TX-AD21D	K3TX-AD22D	K3TX-AD23D
	AC voltage	K3TX-VA21D	K3TX-VA22D	K3TX-VA23D
	AC current	K3TX-AA21D	K3TX-AA22D	K3TX-AA23D

Available Output Board Combinations

Output type	Output configuration	Output Boards	Base Units		
			Basic	Set value LED Display	Thumbwheel Switches
Relay contact	3 outputs: H, PASS, L (SPDT)	K31-C1	Yes	Yes	Yes
	5 outputs: HH, H, L, LL (SPST-NO), and PASS (SPDT)	K31-C2	Yes	Yes	---
	5 outputs: HH, H, L, LL (SPST-NC), and PASS (SPDT)	K31-C5	Yes	Yes	---
Transistor	5 outputs (NPN open collector)	K31-T1	Yes	Yes	Yes**
	5 outputs (PNP open collector)	K31-T2	Yes	Yes	Yes**
BCD*	4-digit output (NPN open collector)	K31-B2	Yes	---	---
Linear	4 to 20 mA DC	K31-L1	Yes	---	---
	1 to 5 VDC	K31-L2	Yes	---	---
	1 mV/digit	K31-L3	Yes	---	---
	0 to 5 VDC	K31-L7***	Yes	---	---
	0 to 10 VDC	K31-L8***	Yes	---	---
Communication boards*	RS-232C	K31-S1	Yes	---	---
	RS-485	K31-S2	Yes	---	---
	RS-422	K31-S3	Yes	---	---
Combination output and communication boards	BCD output + 5 transistor outputs (NPN open collector)	K31-B4***	Yes	Yes	Yes**
	4 to 20 mA + 5 transistor outputs (NPN open collector)	K31-L4***	Yes	Yes	---
	1 to 5 V + 5 transistor outputs (NPN open collector)	K31-L5***	Yes	Yes	---
	1 mV/digit + 5 transistor outputs (NPN open collector)	K31-L6***	Yes	Yes	---
	0 to 5 VDC + 5 transistor outputs (NPN open collector)	K31-L9***	Yes	Yes	---
	0 to 10 VDC + 5 transistor outputs (NPN open collector)	K31-L10***	Yes	Yes	---
	RS-485 + 5 transistor outputs (NPN open collector)	K31-S5***	Yes	Yes	---
	RS-422 + 5 transistor outputs (NPN open collector)	K31-S6***	Yes	Yes	---

*For details, refer to *K3TH/K3TR/K3TX Communication Output-type Intelligent Signal Processor Operation Manual*.

**Only H, PASS, and L outputs are available as transistor outputs on Thumbwheel Switches Models.

*** Special specifications

Base Unit (4 1/2-digit Models)

Model	Input type	Supply voltage	
		100 to 240 VAC	12 to 24 VDC
Basic Models These models provide a present value LED and front-panel control keys. Can be connected to available Output Board, or can be used for display only without an Output Board.	DC voltage	K3TX-VD31A	K3TX-VD32A
	DC current	K3TX-AD31A	K3TX-AD32A

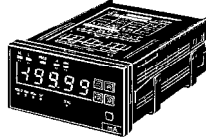

Available Output Board Combinations

Output type	Output configuration	Output Boards	Base Units
			Basic
Relay contact	3 outputs: H, PASS, L (SPDT)	K31-C1	Yes
	5 outputs: HH, H, L, LL (SPST-NO), and PASS (SPDT)	K31-C2	Yes
	5 outputs: HH, H, L, LL (SPST-NC), and PASS (SPDT)	K31-C5	Yes
Transistor	5 outputs (NPN open collector)	K31-T1	Yes
	5 outputs (PNP open collector)	K31-T2	Yes
BCD*	4 1/2-digit output (NPN open collector)	K31-B2	Yes
Linear	4 to 20 mA DC	K31-L1	Yes
	1 to 5 VDC	K31-L2	Yes
	1 mV/digit	K31-L3	---
	0 to 5 VDC	K31-L7**	Yes
	0 to 10 VDC	K31-L8**	Yes
Communication boards*	RS-232C	K31-S1	Yes
	RS-485	K31-S2	Yes
	RS-422	K31-S3	Yes
Combination output and communication boards	BCD output + 5 transistor outputs (NPN open collector)	K31-B4**	Yes
	4 to 20 mA + 5 transistor outputs (NPN open collector)	K31-L4**	Yes
	1 to 5 V + 5 transistor outputs (NPN open collector)	K31-L5**	Yes
	1 mV/digit + 5 transistor outputs (NPN open collector)	K31-L6**	---
	0 to 5 VDC + 5 transistor outputs (NPN open collector)	K31-L9**	Yes
	0 to 10 VDC + 5 transistor outputs (NPN open collector)	K31-L10**	Yes
	RS-485 + 5 transistor outputs (NPN open collector)	K31-S5**	Yes
	RS-422 + 5 transistor outputs (NPN open collector)	K31-S6**	Yes

*For details, refer to *K3TH/K3TR/K3TX Communication Output-type Intelligent Signal Processor Operation Manual*.

** Special specifications

Appendix B

Specifications

Specifications and Ratings

The following lists the ratings and characteristics of the K3TX Intelligent Signal Processor:

Ratings

Supply voltage (see note 1)	100 to 240 VAC (50/60 Hz); 12 to 24 VDC; 48 to 110 VDC
Operating voltage range	85% to 110% of supply voltage (48 to 110 VDC: 85% to 115%)
Power consumption (see note 2)	15 VA max. (at max. AC load); 10 W max. (at max. DC load)
Insulation resistance	10 MΩ min. (at 500 VDC) between external terminal and case
Dielectric withstand voltage	2,000 VAC for 1 min between external terminal and case
Noise immunity	±1,500 V on power supply terminals in normal or common mode (square-wave noise with 1 μs, 100-ns)
Vibration resistance	Malfunction: 10 to 55 Hz, 0.5-mm double-amplitude (approx. 7G) for 10 min each in X, Y, and Z directions Destruction: 10 to 55 Hz, 0.75-mm double-amplitude (approx. 10G) for 2 hrs each in X, Y, and Z directions
Shock resistance	Malfunction: 98 m/s ² (10G) for 3 times each in X, Y, and Z directions Destruction: 294 m/s ² (30G) for 3 times each in X, Y, and Z directions
Ambient temperature	Operating: -10° to 55°C (with no icing) Storage: -20° to 65°C (with no icing)
Ambient humidity	Operating: 35% to 85% (with no condensation)
Ambient atmosphere	Must be free of corrosive gas
EMC	Emission Enclosure: EN55011 Group 1 class A Emission AC Mains: EN55011 Group 1 class A Immunity ESD: EN61000-4-2: 4 kV contact discharge (level 2) 8 kV air discharge (level 3) Immunity RF-interference: ENV50140: 10 V/m (amplitude modulated, 80 MHz to 1 GHz) (level 3) 10 V/m (pulse modulated, 900 MHz) Immunity Conducted Disturbance: ENV50141: 10 V (0.15 to 80 MHz) (level 3) Immunity Burst: EN61000-4-4: 2 kV power-line (level 3) 2 kV I/O signal-line (level 4) Performance Criterion: EMS: 0.1% rdg±30 digits display range
Approved standards	UL (File No. E4151), CSA (File No. LR67027); conforms to EN50081-2, EN50082-2, EN61010-1 (IEC1010-1)

- Note**
1. The supply voltage varies with the model.
 2. An Intelligent Signal Processor requires a control power supply current of approximately 1 A the moment the Intelligent Signal Processor is turned on. Do not forget to take this into consideration when using several Intelligent Signal Processors.

Characteristics

Input signal (see note 1)	DC voltage/current, AC voltage/current
A/D conversion method	Double integral method
Sampling period	50 Hz: 12.5 times/s; 60 Hz: 15 times/s (selectable)
Display refresh period	Sampling period/1.0/2.0/3.0/4.0 s (switch selectable)
Max. displayed digits	4 digits (± 9999), $4\frac{1}{2}$ -digits (± 19999)
Display	7-segment LED
Polarity display	"-" is displayed automatically with a negative input signal.
Zero display	Leading zeros are not displayed.
Scaling function	Programmable with front-panel key inputs (range of display: 4-digit series ± 9999 with a decimal position of 10^{-1} to 10^{-3}) 4 $\frac{1}{2}$ -digit Series: ± 19999 with a decimal position of 10^{-1} to 10^{-4}
HOLD function	Maximum hold (maximum data) Minimum hold (minimum data)
External controls (valid at the rising edge of input)	HOLD: (Process value held) RESET: (Maximum/minimum data reset, measurement reset) ZERO: (Forced zero)
Comparative output hysteresis setting	Programmable with front-panel key inputs (001 to 999 digits).
Other functions	Set value protect (for Thumbwheel Switches Models with comparative outputs only) Variable linear output range (for models with linear outputs only)
Output configuration (see note 2)	Relay contact outputs (5 or 3 outputs), Transistor outputs (NPN open collector), Parallel BCD outputs (NPN open collector), Linear output (4 to 20 mA, 1 to 5 V, mV/digit), Communication functions (RS-232C, RS-485, RS-422)
Delay in comparative outputs (at transistor output)	DC input: 200 ms max. AC input: 400 ms max.
Enclosure ratings	Front panel: Refer to IEC IP50 Rear case: Refer to IEC IP20 Terminals: Refer to IEC IP00

- Note**
1. The input signal varies with the model.
 2. The output configuration varies with the model.

I/O Ratings

The following tables list the various I/O Ratings. These I/O Ratings are categorized according to: Contact Output, Transistor Output, I/O Ratings of BCD Output, and Linear Output.

Relay Contact Output

Item	Resistive load ($\cos\phi = 1$)	Inductive load ($\cos\phi = 0.4$, L/R = 7 ms)
Rated load	5 A at 250 VAC; 5 A at 30 VDC	1.5 A at 250 VAC, 1.5 A at 30 VDC
Rated carry current	5 A max. (at COM terminal)	
Max. contact voltage	380 VAC, 125 VDC	
Max. contact current	5 A max. (at COM terminal)	
Max. switching capacity	1,250 VA, 150 W	375 VA, 80 W
Min. permissible load	10 mA at 5 VDC	

Transistor Output

Rated load voltage	12 to 24 VDC $+10\%/ -15\%$
Max. load current	50 mA
Leakage current	100 μ A max.

BCD Output

I/O signal name		Item	Rating
Inputs	REQUEST	Input voltage	No-voltage contact input
	HOLD MAX REQ. MIN REQ. RESET	Input current	10 mA
		Operating voltage	ON: 1.5 V max. OFF: 3 V min.
Outputs	DATA POLARITY	Rated load voltage	12 to 24 VDC ^{+10%} / _{-15%}
	DATA OVERFLOW DATA VALID	Max. load current	10 mA
	RUN	Leakage current	100 μ A max.

Note: Logic method: negative logic

Linear Output

Item	4 to 20 mA	1 to 5 V	mV/digit
Resolution	4,096 resolution		
Output tolerance	$\pm 0.5\%$ FS		---
Permissible load resistance	600 Ω max.	500 Ω min.	1 K Ω min.

Measuring Ranges

K3TX-□□2□□-□□ (4-digit Models)

Input range		Measuring range	Input impedance	Reliability (at 25°C \pm 5°C)	Instantaneous overload (approx. 30 s)
DC voltage	a	± 199.9 V	10 M Ω	$\pm 0.1\%$ rdg ± 1 digit max.	± 400 V
	b	± 99.99 V	10 M Ω	$\pm 0.1\%$ rdg ± 1 digit max.	± 400 V
	c	± 9.999 V	1 M Ω	$\pm 0.1\%$ rdg ± 1 digit max.	± 200 V
	d	± 999.9 mV	10 M Ω min.	$\pm 0.1\%$ rdg ± 1 digit max.	± 200 V
	e	± 99.99 mV	10 M Ω min.	$\pm 0.1\%$ rdg ± 1 digit max.	± 200 V
	f	1.000 to 5.000 V	1 M Ω	$\pm 0.1\%$ rdg ± 1 digit max.	± 200 V
DC current	a	± 199.9 mA	1 Ω	$\pm 0.1\%$ rdg ± 1 digit max.	± 400 mA
	b	± 99.99 mA	1 Ω	$\pm 0.1\%$ rdg ± 1 digit max.	± 400 mA
	c	± 9.999 mA	10 Ω	$\pm 0.1\%$ rdg ± 1 digit max.	± 200 mA
	d	4.00 to 20.00 mA	10 Ω	$\pm 0.1\%$ rdg ± 1 digit max.	± 200 mA
AC voltage	a	0 to 400 V	1 M Ω	$\pm 0.3\%$ rdg ± 5 digit max.	700 V
	b	0 to 99.99 V	1 M Ω	$\pm 0.3\%$ rdg ± 5 digit max.	400 V
	c	0 to 9.999 V	1 M Ω	$\pm 0.3\%$ rdg ± 5 digit max.	400 V
AC current	a	0 to 10.00 A	(0.5 VA CT)	$\pm 0.5\%$ rdg ± 7 digit max.	20 A
	b	0 to 1.999 A	(0.5 VA CT)	$\pm 0.5\%$ rdg ± 5 digit max.	20 A
	c	0 to 199.9 mA	1 Ω	$\pm 0.3\%$ rdg ± 3 digit max.	2 A
	d	0 to 99.99 mA	1 Ω	$\pm 0.3\%$ rdg ± 5 digit max.	2 A

K3TX-□D3□A-□□ (4¹/₂-digit Models)

Input range		Measuring range	Input impedance	Reliability (at 25°C \pm 5°C)	Instantaneous overload (approx. 30 s)
DC voltage	a	± 199.99 V	10 M Ω	$\pm 0.1\%$ rdg ± 1 digit max.	± 400 V
	b	± 19.999 V	1 M Ω	$\pm 0.1\%$ rdg ± 1 digit max.	± 200 V
	c	± 1.9999 V	1 M Ω	$\pm 0.1\%$ rdg ± 1 digit max.	± 200 V
	d	± 199.99 mV	10 M Ω min.	$\pm 0.1\%$ rdg ± 1 digit max.	± 200 V
	e	1.000 to 5.000 V	1 M Ω	$\pm 0.1\%$ rdg ± 1 digit max.	± 200 V
DC current	a	± 199.99 mA	1 Ω	$\pm 0.1\%$ rdg ± 1 digit max.	± 400 mA
	b	± 19.999 mA	10 Ω	$\pm 0.1\%$ rdg ± 1 digit max.	± 200 mA
	c	4.00 to 20.00 mA	10 Ω	$\pm 0.1\%$ rdg ± 1 digit max.	± 200 mA

Communications Specifications

The following lists the Intelligent Signal Processor specifications related to communications.

Item		RS232C, RS422	RS485
Transmission method		4-wire, half-duplex	2-wire, half-duplex
Synchronization method		Start-stop synchronization	
Baud rate		150/300/600/1,200/2,400/4,800/9,600/19,200/38,400	
Transmission code		ASCII (7-bit)	
Communications	Write to K3TX	Set values, reset control (maximum/minimum values)	
	Read from K3TX	Set values, process value, maximum/minimum values, model data, error code, etc.	

List of Factory-set Parameters

K3TX-□□2□□-□□ (4-digit Models)

Setting level	Content of menu	Displayed characters	Initial value				
			DC (V)	DC (A)	AC (V)	AC (A)	
Level 1	Set value	cset	HH	199.9	199.9	400.0	10.00
			H	199.9	199.9	400.0	10.00
			L	-199.9	-199.9	0.0	0.00
			LL	-199.9	-199.9	0.0	0.00
	Hysteresis	hys		001	001	001	001
	Prescaling value	scal	X ₂	199.9	199.9	400.0	10.00
			Y ₂	1999	1999	400.0	10.00
			X ₁	-199.9	-199.9	0.0	0.00
			Y ₁	-1999	-1999	00	000
			Decimal point	%%%.%	%%%.%	%%%.%	%%.%%
	Linear output range	lset	LH	199.9	199.9	400.0	10.00
			LL	-199.9	-199.9	0.0	0.00
	Set value protect	prot		off	off	off	off
	Level 2	Input range	in-t	a Ud	a ad	a Ua	a aa
Supply frequency		s-6	50	50	50	50	
Display refresh period		disp	fast	fast	fast	fast	
Unit no.		u-no	00	00	00	00	
Baud rate		bps	9600	9600	9600	9600	
Lock timer		lock				00.0	

Note The lock timer is available only on special models.

K3TX-□D3□A-□□ (4¹/₂-digit Models)

Setting level	Content of menu	Displayed characters		Initial value	
				DC (V)	DC (A)
Level 1	Set value	cset	HH	199.99	199.99
			H	199.99	199.99
			L	-199.99	-199.99
			LL	-199.99	-199.99
	Hysteresis	hys		001	001
	Prescaling value	scal	X ₂	199.99	199.99
			Y ₂	19999	19999
			X ₁	-199.99	-199.99
			Y ₁	-19999	-19999
			Decimal point		%%%.%%%
Level 2	Set value protect	prot		off	off
	Input range	in-t		a Ud	a ad
	Supply frequency	s--6		50	50
	Display refresh period	disp		fast	fast

Interface Specifications

RS-232C

Electrical characteristics: Conforms to EIA RS-232C

Communications Signals

The following information identifies the key input/output signals of the interface.

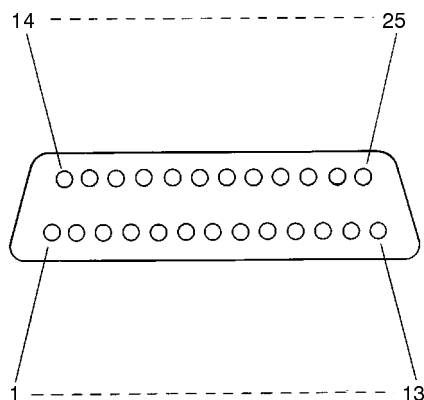

Signal	Abbreviation	Signal direction	Pin no.
Frame Ground (safety ground)	FG	---	1
Signal Ground or common return	SG	---	7
Send Data	SD	Output	2
Receive Data	RD	Input	3
Request To Send	RS	Output	4
Can Send	CS	Input	5
Data Set Ready	DR	Input	6
Data Terminal Ready	ER	Output	20

Connection Diagram

The following example provides information on how the RS-232C Intelligent Signal Processor is to be connected to the host computer.

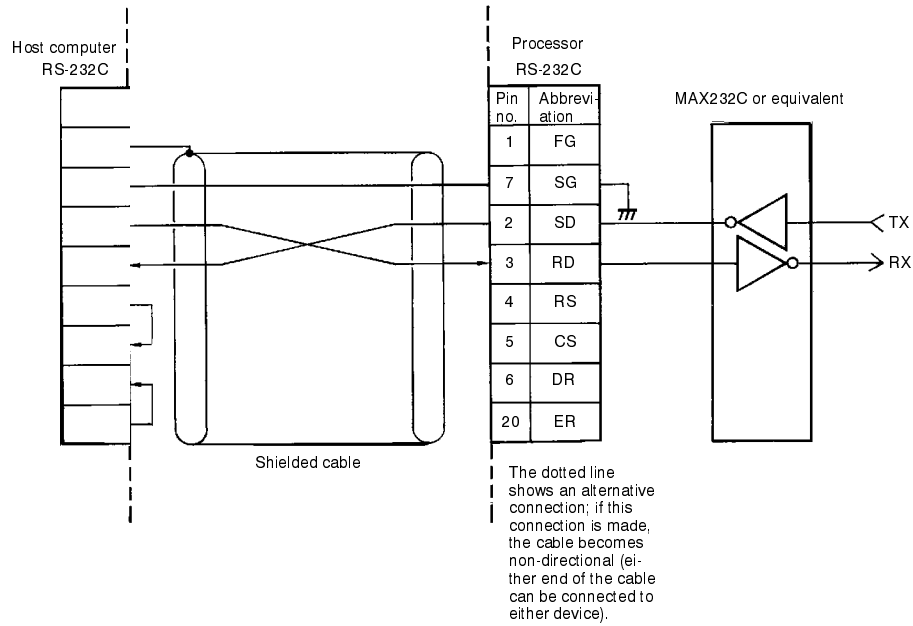

Synchronization clock: Internal clock

Cable length: 15 m maximum. If increasing the cable length, use OMRON's RS-232C optical interface (Z3RN).

Applicable connectors: Plug: XM2A-2501 (OMRON) or equivalent
 Hood: XM2S-2511 (OMRON) or equivalent

Connection method (RS-232C direct connection): 1:1 connection only

RS-422

Electrical characteristics: Conforms to EIA RS-422

Communications Signals

The following information identifies the key input/output signals of the interface.

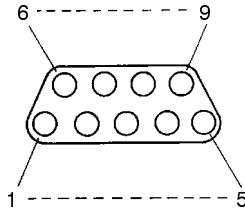

Signal	Abbreviation	Signal direction	Pin no.
Send Data A	SDA	Output	9
Send Data B	SDB	Output	5
Receive Data A	RDA	Input	6
Receive Data B	RDB	Input	1
Signal Ground	SG	---	3
Frame Ground (safety ground)	FG	---	7

Connection Diagram

The following example provides information on how the RS-422 Intelligent Signal Processor is to be connected to the host computer.

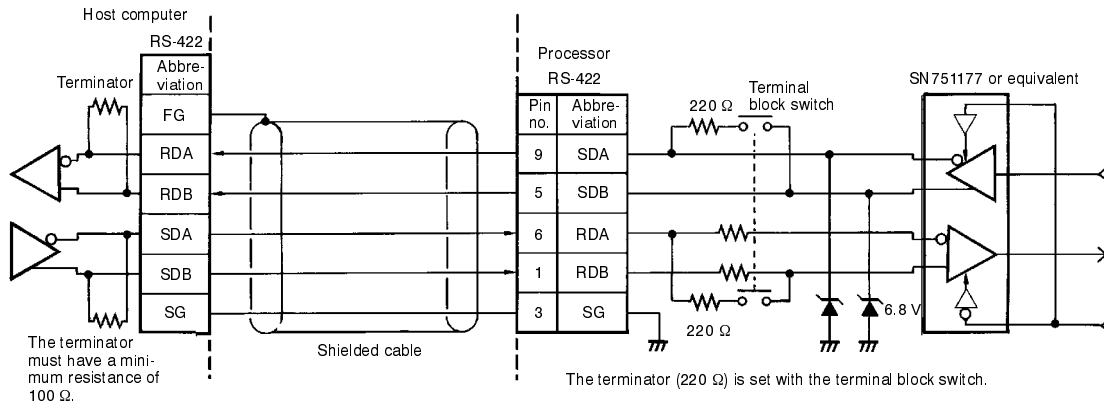

Synchronization clock: Internal clock

Total line length: 500 m maximum

Recommended cable: CO-HC-ESV-3P x 7/0.2 (Hirakawa Densen)

Applicable connectors: Plug: XM2A-0901 (OMRON) or equivalent
 Hood: XM2S-0911 (OMRON) or equivalent

Connection method (RS-422 connection): Maximum 1:32 connection

When using this connection:

- Turn ON the terminal block switch at the end station.
- Turn OFF all other terminal block switches.

RS-485

Electrical characteristics: Conforms to EIA RS-485

Communications Signals

The following information identifies the key input/output signals of the interface.

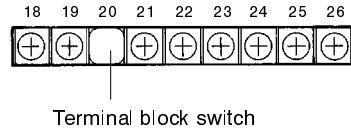

Signal	Abbreviation	Signal direction	Terminal No.
Inverted output	Negative (-) side	Input/output	19
Non-inverted output	Positive (+) side	Input/output	18

Connection Diagram

The following example provides information on how the RS-485 Intelligent Signal Processor is to be connected to the host computer.

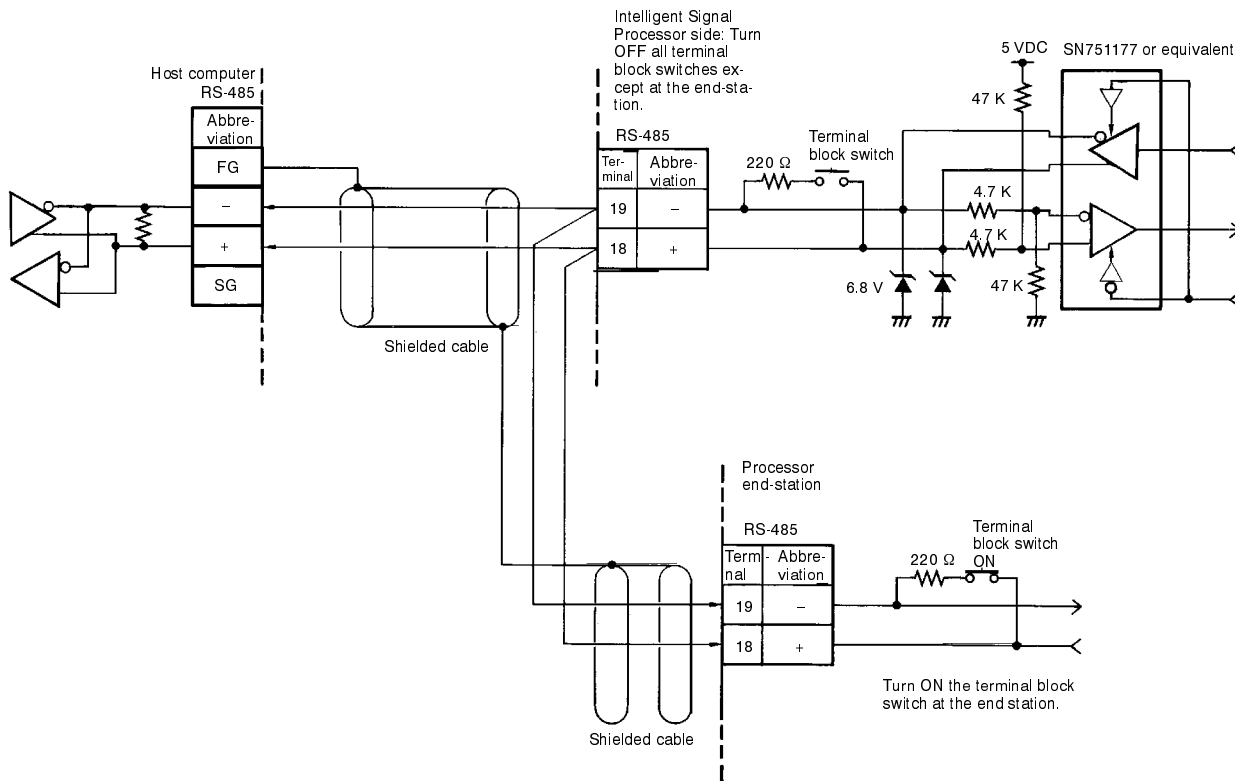

Synchronization clock: Internal clock

Total line length: 500 m maximum

Recommended cable: CO-HC-ESV-3P x 7/0.2 (Hirakawa Densen)

Connection method (RS-485 connection): Maximum 1:32 connection

In this case, the SYSMAC SYSBUS wire type cannot be connected.

Terminal Numbers

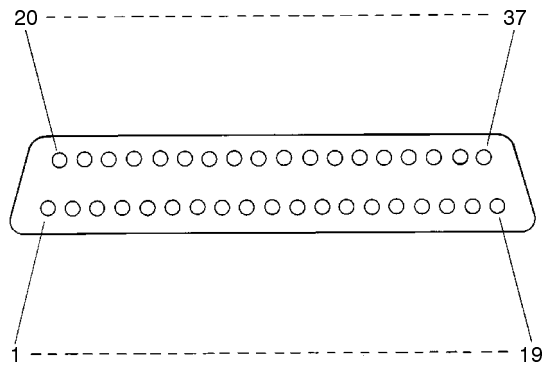

Terminal no.	Signal name	Signal direction	Description
1	COM	---	GND: VO (See Note 1)
2	DATA	Output	1 Read data: 10 ⁰ digit
3		Output	2 Read data: 10 ⁰ digit
4		Output	4 Read data: 10 ⁰ digit
5		Output	8 Read data: 10 ⁰ digit
6		Output	1 Read data: 10 ¹ digit
7		Output	2 Read data: 10 ¹ digit
8		Output	4 Read data: 10 ¹ digit
9		Output	8 Read data: 10 ¹ digit
10		Output	1 Read data: 10 ² digit
11		Output	2 Read data: 10 ² digit
12		Output	4 Read data: 10 ² digit
13		Output	8 Read data: 10 ² digit
14		Output	1 Read data: 10 ³ digit
15		Output	2 Read data: 10 ³ digit
16		Output	4 Read data: 10 ³ digit
17		Output	8 Read data: 10 ³ digit
18		Output	1 Read data: 10 ⁴ digit
19		Output	2 Read data: 10 ⁴ digit
20		Output	4 Read data: 10 ⁴ digit
21		Output	8 Read data: 10 ⁴ digit
22		OVER	Output
23	DATA VALID	Output	Data confirmation signal
24	RUN	Output	Operation signal
25	COM	---	GND: VO (See Note 1)
26	REQ	Input	PV output request
27	Max.	Input	Maximum value output request
28	Min.	Input	Minimum value output request
29	HOLD	Input	Hold input
30	RESET	Input	Reset input
31	POL	Output	Positive/negative polarity signal
32	HH	Output	HH comparative output (See Note 2)

Terminal no.	Signal name	Signal direction	Description
33	H	Output	H comparative output (see note 2)
34	PASS	Output	PASS comparative output (see note 2)
35	L	Output	L comparative output (see note 2)
36	LL	Output	LL comparative output (see note 2)
37	COM	Output	GND: VO (see note 1 and 2)

- Note**
- Terminals No. 1, 25, and 37 have the same COM.
 - Terminals No. 32 through 36 are effective only in special models.

Applicable Connectors

Plug: XM2A-3701 (OMRON) or equivalent
 Hood: XM2S-3711 (OMRON) or equivalent

Operation

When a REQ signal is input to the Processor from a PC, the data is confirmed after an interval of 30 ms, and a DATA VALID (D.V.) signal is output from the Processor. Read the data when the DATA VALID signal is ON.

Connection between PC and Processor should be performed with a rear panel transmission connector.

When one PC Unit is connected with several Processor Units, it is possible to achieve a wired OR connection between the DATA (POL, OVER) and DATA VALID signals.

Data cannot be written from a PC to a Processor.

Timing Charts

Sampling Data Output (at Each Sample)

Data is confirmed after 30 ms from the REQ signal rising time, and DATA VALID signal is output. Read data while DATA VALID signal ON. The DATA VALID signal is turned OFF after an interval of 40 ms, then data is turned OFF after an interval of 16 ms.

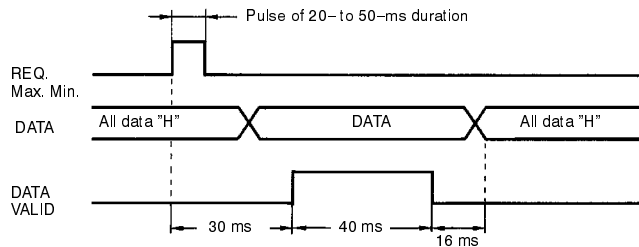

Continuous Data Output

When the REQ signal remains ON, measurement data is output at intervals of 64 ms. When a hold operation or another operation is performed during the change from DATA 1 to DATA 2, the BCD data output is either DATA 1 or DATA 2 at the hold signal timing. Read maximum or minimum data when DATA VALID signal turns ON, after a 30 ms interval from maximum or minimum signal ON time to confirm measurement data.

The RUN signal is ON during RUN mode or TEST mode. (Note that the RUN signal is turned OFF when an error other than overflow or underflow occurs.)

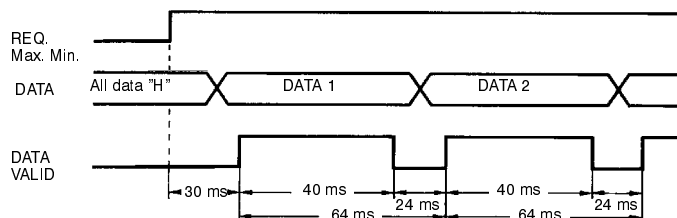

When a HOLD signal is input, the Processor stops accepting input and the data received just before the HOLD signal is retained and displayed. The same function is available in (5)-(7) terminal ON.

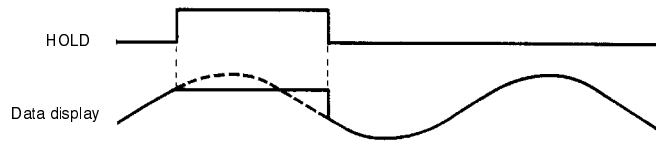

When RESET signal is input (ON), the maximum or minimum value becomes the current PV value.

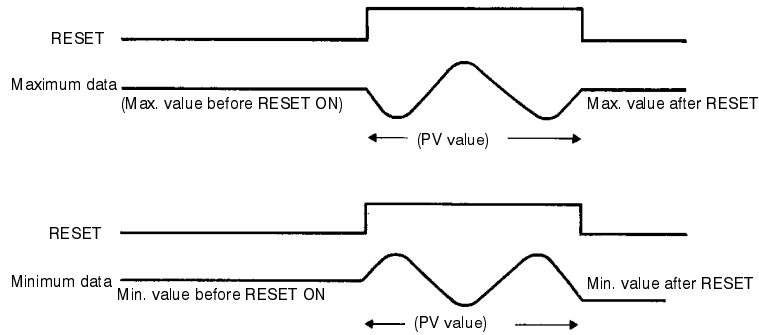

POL output becomes L at positive (+) pole or H at negative (-) pole.

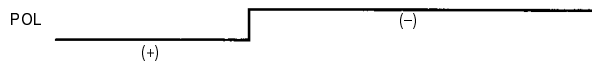

OVER output is formed when BCD output data becomes overflow or underflow data.

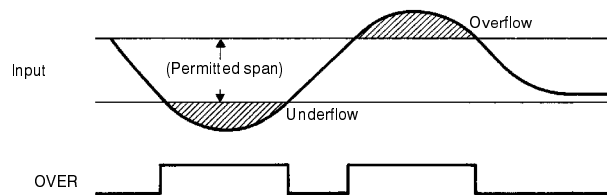

In set value parameter or prescaling parameter, no BCD output is formed (All outputs become "H"). In TEST mode, the test PV value currently input is output in both REQ maximum and REQ minimum signals. When two or more input signals are input simultaneously, or when a signal is input during another input, all the output data is turned OFF. Do not turn ON two or more input signals at the same time (except for the HOLD signal).

Index

A–C

AC Current Input, 22
AC Voltage Input, 22
ANALOG COMMON, 16
application examples, 3
baud rate, 44
COM, 16, 17
communications unit number, 43
comparative output status indicators
 K3TX 4 1/2-digit Basic Model, 12
 K3TX 4-digit Basic Model, 6
 K3TX with Set Value LED Display, 8
 K3TX with Thumbwheel Switches, 10
continuous data output, timing charts, interface, 76

D

DATA TEACH Key
 K3TX 4 1/2-digit Basic Model, 13
 K3TX 4-digit Basic Model, 7
 K3TX with Set Value LED Display, 9
 K3TX with Thumbwheel Switches, 11
DC Current Input
 4 1/2-digit Series, 23
 4-digit Series, 22
DC Voltage Input
 4 1/2-digit Series, 23
 4-digit Series, 22
device failure, 62
dimensions, 20
Display Key
 K3TX 4 1/2-digit Basic Model, 13
 K3TX 4-digit Basic Model, 7
 K3TX with Set Value LED Display, 9
 K3TX with Thumbwheel Switches, 11
display refresh period, 2, 35

F

factory-set parameters list, 70
forced zero, 2, 56
front panel nomenclature and functions
 K3TX 4 1/2-digit Basic Model, 12
 K3TX 4-digit Basic Model, 6
 K3TX with Set Value LED Display, 8
 K3TX with Thumbwheel Switches, 10

H–I

HOLD, 16, 55
hold measured value, 2
hysteresis, 2, 39
I/O ratings
 BCD output, 69
 linear output, 69
 relay contact output, 68
 transistor output, 68
input models
 4-digit Series, 22
 AC Current Input, 22
 AC Voltage Input, 22
 DC Current Input, 4 1/2-digit Series, 23
 DC Voltage Input
 4 1/2-digit Series, 23
 4-digit Series, 22
input range, 2, 30
input specification error, 62
inputs, 16
 ANALOG COMMON, 16
 COM, 16, 17
 HOLD, 16
 measurement input, 16
 power, 16
 RESET, 16
 unused terminals, 17
 ZERO, 17
interface specifications, 71
 operating considerations, 76
 RS-232C, 71
 RS-422, 73
 RS-485, 74
 terminal numbers, 75
 timing charts, 76
 continuous data output, 76
 sampling data output, 76
internal circuit block diagram, 4

L–M

Level Key
 K3TX 4 1/2-digit Basic Model, 13
 K3TX 4-digit Basic Model, 7
 K3TX with Set Value LED Display, 9
 K3TX with Thumbwheel Switches, 11
linear output range, 41
lock timer, 2, 46, 56
maximum/minimum values
 resetting, 2, 53
 retaining, 2, 53
measurement input, 16
models, standard, 63

O

operation keys

- DATA TEACH Key, 7, 9, 11, 13
- Display Key, 7, 9, 11, 13
- K3TX 4 1/2-digit Basic Model, 13
- K3TX 4-digit Basic Model, 7
- K3TX with Set Value LED Display, 9
- K3TX with Thumbwheel Switches, 11
- Level Key, 7, 9, 11, 13
- Shift Key, 7, 9, 11, 13
- Up Key, 7, 9, 11, 13

operations

- RUN mode, 48
- special functions, 57

operations in RUN mode

- changing set values, 50
- checking set values, 48
- forced zero, 56
- HOLD, 55
- lock timer, 56
- resetting maximum/minimum values, 53
- retaining maximum/minimum values, 53

Output Models

- change, 62
- error, 62

outputs, 18

overflow, 62

P—R

panel mounting, 20

parameters

- before setting the parameters, 26
- list of parameters for each model, 28
- operations, 48
- setting, 30
- setting procedure, 28

power, 16

prescaling, 33

- prescale value, 2

process value display

- K3TX 4 1/2-digit Basic Model, 12
- K3TX 4-digit Basic Model, 6
- K3TX with Set Value LED Display, 8
- K3TX with Thumbwheel Switches, 10

PV display

- K3TX 4 1/2-digit Basic Model, 12
- K3TX 4-digit Basic Model, 6
- K3TX with Set Value LED Display, 8
- K3TX with Thumbwheel Switches, 10

PV display status indicators

- K3TX 4 1/2-digit Basic Model, 12
- K3TX 4-digit Basic Model, 6
- K3TX with Set Value LED Display, 8
- K3TX with Thumbwheel Switches, 10

ratings, 67

- I/O, 68

RESET, 16

RS-232C, specifications, 71

RS-422, specifications, 73

RS-485, specifications, 74

S

sampling data output, timing charts, interface, 76

set value, protecting, 40

set value display, K3TX with Set Value LED Display, 8

set values, 2, 37

- changing, 2
- checking, 2
- protecting, 2

setting, 2

- baud rate, 44
- communications unit number, 43
- display refresh period, 35
- hysteresis, 39
- input range, 30
- level of setting mode and parameters, 26
- linear output range, 2, 41
- lock timer, 46
- parameter setting procedure, 28
- prescaling, 33
- procedure, 27
- set values, 37
- supply frequency, 32

Shift Key

- K3TX 4 1/2-digit Basic Model, 13
- K3TX 4-digit Basic Model, 7
- K3TX with Set Value LED Display, 9
- K3TX with Thumbwheel Switches, 11

special functions, 57

- teaching function, 59
- test function, 57

specifications, 67

- communications, 70

supply frequency, 2, 32

SV display, K3TX with Set Value LED Display, 8

SV display status indicator, K3TX with Set Value LED Display, 8

T

teaching function, 3, 59

terminal numbers, interface, 75

test function, 57

test mode, 3

thumbwheel switches, K3TX with Thumbwheel Switches, 10

timing charts, interface, 76

troubleshooting guide, 62

U

underflow, 62

unit

K3TX 4 1/2-digit Basic Model, 12

K3TX 4-digit Basic Model, 6

K3TX with Set Value LED Display, 8

K3TX with Thumbwheel Switches, 10

unused terminals, 17

Up Key

K3TX 4 1/2-digit Basic Model, 13

K3TX 4-digit Basic Model, 7

K3TX with Set Value LED Display, 9

K3TX with Thumbwheel Switches, 11

Z

ZERO, 17

zero suppress, 50, 60

zero-shift, 2, 56

Revision History

A manual revision code appears as a suffix to the catalog number on the front cover of the manual.

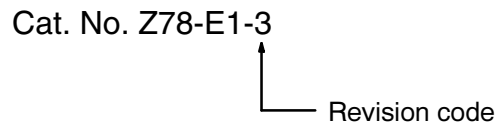

The following table outlines the changes made to the manual during each revision. Page numbers refer to the previous version.

Revision code	Date	Revised content
1	October 1991	Original production
2	August 1994	<p>Information relating to the K3TX 4¹/₂-digit Display model has been added throughout the manual. Distinctions between 4-digit and 4¹/₂-digit models have been made throughout the manual.</p> <p>Page 2: Display Refresh Period, Set Values, and Protecting, Checking, and Changing Set Values have been rewritten.</p> <p>Pages 7 to 11: Display and indicator functions have been corrected and rewritten.</p> <p>Pages 14, 15: Functions for inputs 1 to 3, 6, 8, 9, and 13 corrected.</p> <p>Page 16: K31-B2: BCD (NPN Open Collector) terminal diagram corrected.</p> <p>Page 20: K3TX-□□2□□-□□ (4-digit Series) graphs corrected.</p> <p>Page 22: Information added to block diagram.</p> <p>Page 24: Sensor change corrected to input range for Parameter Setting Procedure diagram.</p> <p>Page 26: Input range tables corrected. Input range tables added.</p> <p>Page 29: Setting range table, graph and flowchart added.</p> <p>Page 33: First paragraph rewritten. Setting range table corrected.</p> <p>Page 36: First paragraph rewritten.</p> <p>Page 37: Linear Output Range rewritten.</p> <p>Page 45: Second paragraph added.</p> <p>Pages 46, 48: Text rewritten.</p> <p>Page 51: Lock Timer rewritten.</p> <p>Page 52: Teaching function in Special Functions rewritten.</p> <p>Page 54: Teaching function graphs and information added.</p> <p>Page 59: Standard Models updated.</p> <p>Pages 61 to 64: Data corrected and added to.</p> <p>Page 64: Interface Specifications added.</p>
3	October 1996	<p>Page 2: <i>Input Range Models</i> and <i>Prescaling</i> descriptions rewritten.</p> <p>Pages 16, 17: Note added for HOLD input.</p> <p>Page 18: Description added for <i>K31-B2: BCD (NPN Open Collector)</i>. Plug models corrected for RS-232C and RS-422 at the bottom of the page.</p> <p>Pages 22, 23: Minor corrections to the charts.</p> <p>Page 23: Model number correction in the first sentence.</p> <p>Page 33: Model number correction in the second row of table.</p> <p>Page 41: Description added to second paragraph.</p> <p>Pages 63, 64: Models lists replaced.</p> <p>Page 65: <i>Approved standards</i> added to and <i>Note</i> rewritten and added to. EMC added.</p> <p>Page 66: Clarifications made to <i>Other functions</i> and <i>Delay in comparative outputs</i>. <i>Note</i> rewritten and added to.</p> <p>Page 71: Minor correction to the connection diagram.</p> <p>Page 74: Note 2 corrected. Minor corrections made to the timing charts.</p>



OMRON ELECTRONICS LLC

1 Commerce Drive
Schaumburg, IL 60173
847.843.7900
For US technical support or
other inquiries: 800.556.6766

OMRON CANADA, INC.

885 Milner Avenue
Toronto, Ontario M1B 5V8
416.286.6465

OMRON ON-LINE

Global - <http://www.omron.com>
USA - <http://www.omron.com/oei>
Canada - <http://www.omron.ca>

UNITED STATES

To locate a Regional Sales Office, local Distributor or
to obtain product information, call: 847.843.7900

CANADA REGIONAL SALES OFFICES

Ontario	Toronto	416.286.6465
	Kitchener	519.896.1144
	Kingston	613.376.3968
Quebec	Montreal	514.636.6676
British Columbia	Vancouver	604.522.8855
Alberta	Edmonton	403.440.0818
	Calgary	403.257.3095

BRAZIL SALES OFFICE

Sao Paulo 55.11.5564.6488

ARGENTINA SALES OFFICE

Cono Sur 54.114.787.1129

MEXICO SALES OFFICES

Florida 954.227.2121 **Ciudad Juarez** 656.623.7083
Mexico, D.F. 555.534.1195 **Monterrey, N.L.** 818.377.4281